



PDHonline Course C313 (3 PDH)

Underwater Sampling of Soils

Instructor: John Huang, Ph.D., PE and John Poullain, PE

2020

PDH Online | PDH Center

5272 Meadow Estates Drive
Fairfax, VA 22030-6658
Phone: 703-988-0088
www.PDHonline.com

An Approved Continuing Education Provider

Chapter F-10 Underwater Sampling of Soils

10-1. Introduction

This chapter is intended to provide guidance for obtaining soil samples in the nearshore environment, such as harbors, rivers, coastal plains, backswamps, and wetlands where the depth of water varies from 0 to 45 m (0 to 150 ft), and is generally less than 20 m (65 ft). Sampling in deep water is not addressed herein. This guidance is intended to support typical projects such as marine construction projects, dredging of channels and harbors, construction of levees and dams, and reclamation of wetlands. Therefore, the information concentrates on common, commercially available sampling equipment and methods. One-of-a-kind research tools or equipment available only from foreign countries is not discussed. Appendix A lists references that discuss some of these topics. However, guidance for obtaining chemical samples, which is typically done in conjunction with soil sampling, is beyond the scope of this manual. Geotechnical personnel should coordinate underwater chemical sampling with the Project Environmental Engineer, or should refer to EPA Manual 503/8-91 (the “green book”) and the appropriate Regional Implementation Manual.

Generally, sampling soils underwater in the nearshore environment is not significantly different from sampling soils on land. The concerns for obtaining minimally disturbed samples for geotechnical testing are the same; the samples are just more difficult to obtain. In addition to the need to find the right equipment for obtaining samples, a work platform or vessel and a positioning system are needed. The wind, waves, tides, currents, and water depths must also be considered when planning a site investigation.

The selection of appropriate sampling equipment for retrieving underwater samples depends upon several factors: soil data required, sizes of test specimens needed, sediment type, geology, the depth of water or elevation of the seafloor, environmental conditions, vessel availability, and funding limits. These factors do not always favor selections that are compatible. For example, the equipment required to obtain the size and/or quality of sample(s) may not be deployable from the vessel available within the project budget, or the available vessel may not be able to operate in the required shallow-water depths. Each of these factors will be discussed in this chapter.

10-2. Underwater Sediment Types

The selection of appropriate equipment for underwater sampling depends on the type of sediment to be sampled. Because some samplers cannot be used to retrieve a high-quality sample, or in some cases, any sample in certain types of materials, it is important to know beforehand the types of sediments most likely to be encountered at the site.

Marine sediments can be classified according to several criteria (Noorany 1989). In the nearshore environment, marine sediments are classified according to their origin. Lithogenous (derived from rock) sediments are formed from terrestrial or volcanic sources. Underwater lithogenous (terrigenous) sediments result either from a rise in the sea level, the submergence of land due to geological events, or by soil particles being transported by wind, water, or ice to the sea where they settle. Because sampling terrigenous sediments is similar to sampling the same types of soils on land, determination of the source of the sediments and the method by which the deposit was formed can help in predicting whether the sediment is normally consolidated or overconsolidated; this information can be used as a guide for

selecting the best sampling method(s). Biogenic sediments, which are found in both nearshore and deep ocean deposits, are formed from the remains of marine organisms. The most common sediments are either silica (SiO₂) or calcium carbonate (CaCO₃) materials. Hydrogenic sediments are formed by a chemical reaction that occurs under the right conditions of temperature, pressure (water depth), and chemical content of the water and subsequent precipitation of material. Hydrogenous deposits of calcium carbonate can be found nearshore in some areas. Unlike the terrigenous sediments, calcium carbonate sediments are particularly difficult to sample without disturbance; additional information is contained in the proceedings of the international conference on calcareous sediments (Jewell and Khorshid 1988).

10-3. Planning an Underwater Site Investigation

Planning a site investigation on land is discussed in Chapter 2. As compared to an onshore investigation, a nearshore or offshore investigation may encounter some unique problems. To plan an effective offshore investigation, preliminary information should be gathered on the site configuration, environmental conditions, the type of sediment expected to be found at the site, and the sampling equipment and work platforms available and their capabilities. With this information, decisions can be made regarding where to take samples, how many, and to what depth to meet the project requirements. Information on the expected sediment type and the data needed from the samples will determine the type of sampler to use.

One of the first steps is to obtain a marine chart of the area to be surveyed. Suitable charts and maps are available from the National Ocean Service and the National Oceanic and Atmospheric Administration (NOAA) for coastal and Great Lakes areas, the Defense Mapping Agency for open ocean and foreign waters, and the U.S. Army Corps of Engineers for inland rivers, lakes, and canal systems; these documents can be purchased at local marine chandlery stores or ordered from the issuing agency. If the survey site is close to shore, a topographic map of the adjacent land area may also be very helpful. Marine charts normally will show sediment types, water depths, shipping channels, permanent moorings, bridges, buoys, shoals, underwater cables and pipelines, and other items of interest. Water depths are usually referenced to low-water level, whereas bridge clearances are referenced to high-water levels. The date of the chart should be checked and the information on it verified and/or adjusted according to its age. For example, water depths in a harbor may be less than indicated due to sedimentation.

Prior to the investigation, it is suggested that a site visit should be conducted, if possible, to compare the chart with the actual site conditions. Moorings, piers, or other shoreline construction can affect the planning of the survey. While at the site, obtain boat traffic patterns, weather conditions, typical wave heights and currents, and other conditions which could affect the survey. The impact of seasonal events, such as sport boating or fishing seasons, and changes in environmental patterns, such as the deposition and erosion of sediments, weather patterns, or the occurrence of fog, should be investigated. Local tide charts, if applicable, are sometimes available from the harbor master or port services or can be obtained from the National Ocean Service; these charts can be very helpful in planning work for the best use of daylight hours and in conjunction with the tides. Public utility companies should be contacted for updated information if the chart indicates underwater cables or other equipment. The U.S. Coast Guard also provides updated information to the chart in "Notice to Mariners" information on new hazards and changes. The location of onshore structures that could block the navigation system operation and sites which could be used for the navigation system shore stations should be noted.

10-4. Work Platforms for Underwater Sampling

Several types and sizes of work platforms, including scaffolds, barges, and ships, are available to support underwater sampling work. When a platform is selected for a site survey, a number of factors should be considered. These factors include the effects of tides, currents, and depth of water; the positioning of the platform and the capabilities for deploying and retrieving the sampler; the type of sampling equipment as well as the number, size, quality, and depth of samples; safety; and the availability of the equipment. Figure 10-1 shows a small drill rig on a scaffold. Figure 10-2 shows a barge set up for nearshore work. Figure 10-3 shows a jack-up barge that can be used to support an onshore drilling rig. Workboats and drillships are used for sampling in deeper water. A discussion of each of these factors is presented in the following paragraphs.

When a sampling operation is being planned, site data are needed on maximum and minimum water depths, tides, currents, and typical wave heights for the expected weather conditions. The minimum water depths will determine the draft of the vessel that can be used. The height of the vessel, including antennae, navigation equipment, and crane boom, will be important if bridges or other obstacles have to be negotiated.

If samples are required from specified points or locations, then navigation, positioning, and station-keeping systems will affect the type of work platform which is selected. Frequent moves to different locations will require a platform that is easily maneuvered and quickly anchored. The positioning system will depend on the physical characteristics of the site to be surveyed. Vessels typically have from one to four anchors, whereas it may be necessary to install temporary anchors and winches on a barge. Some vessels have bow thrusters which allow them to hold a position without anchoring or with only a minimal number of anchors. If the navigation system on the vessel cannot provide the accuracy required, a supplemental system will have to be employed. With a preplanned investigation, a priority for obtaining samples and their relative locations will allow a more efficient site survey.

The height, reach, and load capacity of the lifting equipment should be specified. Typical types of lifting equipment include cranes, winches, A-frames, and davits. Figure 10-2 shows a barge with a crane, an A-frame, and a winch. The vertical and horizontal clearances for an A-frame should be known because the horizontal clearance varies from the top to the bottom of the A-frame. Figure 10-4 shows a sampling device hung from a pair of davits along the side of a vessel; it can be deployed with winches. Figure 10-5 shows a sampler deployed with a mobile crane mounted on a barge. Because of insufficient deck space, the head of the corer was supported overwater by the crane while its base was placed on the deck as the core was removed.

The support requirements for the sampling device such as power, compressed air, water flow and pressure, deck space and lifting capacity to deploy and retrieve the sampler, and core handling and storage space, need to be considered when the work platform is selected. For example, the type of sampling device should be selected based upon the quality, diameter, and depth of samples needed. However, if the work platform does not have the required support equipment, such as an internal power source or sufficient lifting capacity, then space must be available on the vessel for a generator or positioning an auxiliary A-frame hoist and other support equipment. As an option, alternative types of sampling devices should be considered.

Safety is a very important consideration when a work platform is selected. The vessel should meet U.S. Coast Guard requirements. Life vests and standard personal safety equipment must be provided.

During the coring operation, appropriate shapes (flags) should be displayed indicating the vessel is restricted in its ability to maneuver.

Locating a vessel for an offshore survey can sometimes be difficult. Local harbor masters, port services, or port operations offices can be used as a starting point. Commercial companies have equipment varying from drill ships to workboats to barges for rent; sport fishing boats are also suitable for site work. Many Army installations and Navy bases or shipyards have vessels that can be used. Military reserve units often have vessels that can be used with enough advanced notice. The Military Sealift Command (MSC) and NOAA have many vessels available for offshore work; however, MSC and NOAA require long lead times for scheduling the use of these vessels.

As can be seen by the data in the previous paragraphs, the selection of the work platform is a combination of science and art. No single work platform will satisfy all needs for all nearshore and offshore drilling and sampling operations. The work platform must be selected which will allow the highest quality samples to be obtained at the least cost by using available equipment and techniques applied with experience and sound judgment as dictated by the specific site conditions.

10-5. Underwater Samplers

The choice of an underwater sampler for a particular site investigation depends on the sediment type(s); the type of data needed from the samples; the quality, depth, and diameter of the samples; the depth of water at the site; available work platforms; environmental conditions; and, of course, funding constraints. The most common types of underwater samplers can be divided into three categories based upon the method of deployment, i.e., free samplers, tethered samplers, and drill string samplers. These types of samplers are generally available through commercial enterprises and government agencies. A discussion of each sampler, including its operation, deployment and retrieval requirements, size and quality of sample, the types of sediments in which it can be used, and vessel and support requirements, follows.

a. Free samplers. Untethered samplers, including boomerang samplers, hand-held diver-operated samplers, and remotely operated vehicle (ROV) samplers, can be deployed with minimal attachments to the work platform. Boomerang corers are truly free from any attachment; hand-held diver-operated samplers are dependent upon whether or not the diver is tethered to the work platform; whereas the particular design of ROV samplers determines whether or not they must be tethered.

(1) *Boomerang corer.* The Boomerang corer, as its name implies, returns to the surface after it has been deployed and a sample has been obtained. The corer consists of an expendable ballast portion which contains a plastic core tube connected to two glass floats. To deploy, the sampler is dropped off the work platform and is permitted to free-fall through the water and embed in the seafloor. The sediment-filled core tube is returned to the surface by the glass floats, leaving the expendable ballast portion embedded in the seafloor. The Boomerang corer needs a minimum depth of water of about 10 m (33 ft) to stabilize and obtain its maximum velocity for embedment and maximum sample length. Theoretically, there is no maximum water depth for this device; cores have been obtained from depths exceeding 8,800 m (29,000 ft).

Since the manufacturer provides a detailed manual with the Boomerang corer that is shown in Figure 10-6, only a brief description of the device is presented herein. The corer is 203 cm (80 in.) long overall and weighs 85.7 kg (189 lb) in air and 59.0 kg (130 lb) in water. The expendable ballast portion is a steel shell which serves as the core barrel (lower end) and the float housing (upper end). On the outside of the core barrel is a sliding lead pilot weight attached by a wire to a release lever located in the float housing.

The retrievable and reusable float portion consists of two glass floats and a core tube. The plastic core tube, which is 6.7-cm (2-5/8-in.) ID by 7.3-cm (2-7/8-in.) OD by 122 cm (48 in.) long, is fitted with a stainless steel core catcher in the bottom end and a butterfly valve assembly in the top. The glass floats are attached to the valve assembly; one of the floats usually contains a battery-operated flashing light or pinger to aid in locating the float portion after it has returned to the surface.

The operating sequence of the Boomerang corer is outlined in Figure 10-7:

Step 1: The corer is dropped over the side of the vessel in a vertical orientation. During this operation, care is needed to ensure that sudden swings of the corer are avoided which could cause the pilot weight to slide up the barrel and release the floats.

Step 2: As the corer descends, the hollow rubber ball is compressed by water pressure until it is released, usually at a depth of 10 to 15 m (33 to 49 ft).

Step 3: When the corer embeds in the seafloor sediment, the pilot weight is pushed up with respect to the core barrel, the float release lever is tripped, and the floats are released.

Step 4: As the floats begin to rise, a pin which holds the butterfly valve open is pulled out; this action allows the butterfly valve, which helps to retain the core in the sampling tube, to close. The floats rise and pull the core tube to the surface.

Step 5: When the floats reach the surface, they can be retrieved by hand or by whatever lifting equipment is available. Once the core has been retrieved, the sample should be identified, field logs should be completed, and the sample should be sealed in the plastic tube or placed in a sample jar for storage and shipment to the laboratory.

Although a full length sample is not always obtained in dense sand, a high-quality representative sample of cohesive or cohesionless soils can usually be obtained with the Boomerang corer because of its high-impact velocity. The advantages of this device include the ease in which it may be deployed and retrieved, its relatively accurate positioning on the seafloor as compared to its drop location, and the speed at which a series of cores can be taken. Because of its simplicity, the Boomerang corer can be deployed from almost any vessel or work platform. Depending upon how many corers are being used and how much associated equipment is needed, only a small amount of deck space is usually needed. Tight station-keeping capabilities are not required, although it is a good idea to record the locations where the corers are deployed. Boomerang corers can be deployed in fairly rough seas; the limiting factor is that the vessel must be capable of maneuvering to recover the core. Its disadvantages include the large wall thickness of the core barrel plus liner relative to the core diameter and the short sample length typically obtained for sands.

(2) *Diver-operated hand-held corers.* There are many different versions of diver-operated hand-held corers. Although the operating depths of hand-held corers are controlled by the depth limits imposed on divers (generally less than 30 m or 100 ft), these corers provide a method of sampling areas that are difficult to reach by other coring methods. In general, hand-held corers use a clear plastic core tube that can be pushed or driven into the sediment by a scuba diver. Typically, the core tubes are 3.8 cm (1-1/2 in.) in diameter by 0.6 to 0.9 m (2 to 3 ft) in length, although some larger diameter core tubes are available. Fairly high-quality samples can be obtained in cohesive and cohesionless sediments, although the sample quality and retrieval are dependent upon the diver's skill with the tool. Consequently, training and practice can make a significant difference. The main advantage of this type of corer is that samples

can be obtained from otherwise inaccessible areas. The vessel requirements for supporting the hand-held corer are minimal and are determined mostly by diver needs. The disadvantages include the small diameter of the core and its short length.

One type of hand-held diver-operated corer that is available to government agencies through Naval Facilities (NAVFAC) Ocean Construction Equipment Inventory (OCEI) is described herein. The OCEI corer (Figure 10-8) consists of an aluminum guide frame, a stainless steel hammer, and a core head; it is 119 cm (47 in.) long, weighs 10.4 kg (23 lb) in air and 7.3 kg (16 lb) in water, and can be used to obtain a 3.8-cm- (1-1/2-in.-) diam by 76-cm- (30-in.-) long sample. To obtain a sample, the corer should be placed upright with the base positioning tabs resting on the diver's fins; this placement positions the piston at the seafloor surface. To sample, the clamp on the piston rod is released and the core tube can be pushed into the sediment using the handles on the head. When the core tube can no longer be pushed by the diver (the diver is neutrally buoyant), the hammer can be used to further embed the tube, provided that the free-fall hammer blows are counted. When the core tube is fully embedded, the diver should lock the piston rod clamp before the corer is pulled out of the sediment. Before the diver returns to the support vessel with the core, a cap should be placed on the bottom of the core tube to retain the sample. After the core tube has been removed from the frame, the plastic tube can be cut off at the top of the sample and capped, or the piston can be positioned on top of the sample, the tube filled with seawater, and then capped. The caps on the top and the bottom of the tube should then be taped, the core should be labeled, and the field logs, including the number of free-fall hammer blows, should be updated.

(3) *ROV-operated samplers.* There are some sampling devices that can be operated by the manipulator arms on remotely operated vehicles (ROV). Typically, these samplers are research tools which are designed for use with a specific ROV. Generally, ROV-operated samplers can be used to obtain fairly short, small-diameter cores, are relatively expensive to operate, and are intended for use in deep water. However, there are situations where the ROV device is the best solution to the sampling problem, such as where accessibility is a problem and the depth of water is too great for divers.

b. Tethered samplers. Tethered samplers are attached to the work platform by some type of umbilical support cable or lowering wire, such as a wireline. Tethered samplers can be subdivided into dredges and grab samplers, box corers, gravity corers, and bottom-resting samplers.

(1) *Dredges and grab samplers.* Dredges and grab samplers can be used to obtain disturbed and perhaps nonrepresentative, surficial sediment samples of the seafloor from almost any depth of water. Although there is some overlap between what is called a dredge and a grab, dredges generally are dragged across the seafloor to obtain a sample, whereas grabs have jaws that close after penetrating the seafloor. Examples of each are given in Figure 10-9. Vessel positioning is not critical for the use of these samplers, although some navigational data are needed. Because some components of the seafloor may not be easily sampled, whereas other components may be washed out during sample retrieval, dredge and grab samples are suitable only for identifying the sediment type and should not be used for determining engineering properties. Because of the wide variety of dredge and grab samplers available and the relative simplicity of operation of each, the details for operation and deployment of various samplers are not explored herein.

(2) *Box corers.* A box corer is a device that contains a box which takes a large, relatively undisturbed sample when lowered to the seafloor by a wireline from the work platform. The box corer is pushed into the sediment by its own weight. When the deployment line is retracted, the bottom of the box is closed off by a rotating spade before the box corer is lifted. Most box corers can be operated in any water depth.

Box corers are available from several manufacturers, and therefore the design, size, and operation of each may vary slightly. The boxes are usually constructed of stainless steel or aluminum; sizes range from 10 by 30 by 30 cm (4 by 12 by 12 in.) to 30 by 30 by 90 cm (12 by 12 by 36 in.) to as large as 50 by 50 by 60 cm (20 by 20 by 24 in.). Most boxes have a bottom plate for supporting the sample in transport and a removable side for access to the sample after it has been retrieved. The parts of the box corer and its operational sequence are presented conceptually in Figure 10-10.

The box corer should be prepared for use according to the manufacturer's instructions. Care should be taken to ensure that the safety pins which prevent pretripping are set correctly. After the sampler is lifted off the deck, the pins supporting the weight column should be removed. Safe lowering rates for box corers depend on the seas and the type of device. For example, in calm seas, the box corer can be lowered fairly rapidly but should be slowed considerably as it nears the bottom to allow the corer to stabilize; in rough seas, the box corer should be lowered at a moderate rate and should not be slowed as the corer nears the bottom. When the box corer touches the bottom, deployment of the wireline should be stopped immediately to prevent excess line from getting tangled and interfering with the operation of the corer. If desired, a bottom-sensing pinger can be attached to the wireline; to prevent damage to the pinger during retrieval of the sampler, the wire should be marked to alert the winch operator of the location of the pinger.

After the box has been driven into the sediment by its weight, the corer can be retrieved. As the wireline is recoiled, the spade is rotated to close off the bottom of the box before the box is pulled out of the seafloor. The corer can be retrieved as fast as is possible but should be slowed as it nears the water surface. Once the corer is out of the water, it should not be set on the deck until the weight column support pins have been placed and a rope has been tied around the spade to prevent it from moving as the tension in the wireline is released.

To remove the sample box, a bottom plate must be inserted between the spade and the bottom of the box and clamped before the spade is released and returned to its original position. If the box corer is equipped with an integral spade, the box assembly can be removed from the frame by simply loosening two bolts. After the box sample has been removed from the sampler, the sample can be extruded and subsampled or stored in the box and sealed. Sampling logs for box cores should include information such as the type of box corer, its size, the weight column, the size and/or weight of sample, subsamples taken, and observations or remarks.

Box corers require a midsized vessel with deployment equipment that will provide the height clearance necessary to deploy and retrieve the box. If an A-frame is used, both vertical and horizontal clearances should be checked. The amount of deck space required is typically small; usually a moderate working area plus space for the footprint of the corer is sufficient. Although it is not necessary for the vessel to stay in a fixed position during the sampling operation, position data should be recorded at the instant the corer touches bottom. It should also be noted that core recovery is usually enhanced if the corer is brought to the surface of the water in a nearly vertical retrieval pattern.

The principal advantage of a box corer is that a large, relatively undisturbed sample of cohesive material can be retrieved. The disadvantages of the box corer include the short length of sample which is retrieved and the difficulty of sampling cohesionless sediments which usually wash out of the box corer during retrieval.

(3) *Gravity corers.* Although several types of gravity corers are available, all are operated similarly. In general, gravity corers consist of a large weight on top of a steel core barrel which contains a plastic

liner. The corer is lowered and raised from the seafloor by a wireline, although during the actual sampling process, the corer is allowed to free-fall and penetrate the sediment. Gravity corers can be used in almost any water depth; however, in shallow water, adequate free-fall distance must be available for the sampler to deploy.

Gravity corers have been classified by size or by operational method. Historically, gravity corers were divided into three groups based upon size: Phleger corers, Ewing corers, and deep-ocean corers. Today, several sizes of gravity corers are available; consequently, the operational method, which is based upon the requirement that a valve or internal piston is used to enhance sample recovery, provides a better classification system. Typically, the smaller, shorter corers use a valve and are commonly referred to as “gravity” corers, whereas the larger, longer corers use a piston and are referred to as “piston” corers. A discussion of the gravity and piston corer is presented herein.

(a) *Valve-type gravity corers.* Gravity corers are manufactured by several companies and can be designed to meet almost any coring requirements. The two most common devices are the Phleger and Ewing corers. The Phleger corer, which is shown in Figure 10-11, is typically 0.9 to 1.2 m (3 to 4 ft) long, weighs about 18 kg (40 lb), and can be used to obtain a sample 3.8 cm (1-1/2 in.) in diameter by 0.6 m (2 ft) in length. The Ewing corer, which is illustrated in Figure 10-12, will vary in weight and length depending upon the sample size; the weight of the sampler ranges from 90 to 450 kg (200 to 1,000 lb) and can be used to obtain a sample that is 6 cm (2-1/2 in.) in diameter by 1.8 to 3.0 m (6 to 10 ft) in length. These devices are strikingly similar. The wireline is attached to the bail, which is located at the top of each corer. Below the bail is the weight stand; depending upon the type of sampler, the weights are either permanent or removable. The core barrel, which is lined with a plastic liner and core catcher, is located below the weight stand. A core cutter is attached to the bottom of the core barrel. A check valve, which is used to retain the sample, is located at the top of the weight stand.

Before the gravity corer is deployed, the device should be assembled and inspected according to the manufacturer's instructions. The check valve should be inspected to ensure that it is working properly. If a trip arm release as shown in Figure 10-13 is used, it should be inspected for proper operation and the presence of the safety pin. When the gravity corer is deployed, it can be lowered in the water very rapidly but should be stopped as soon as the trip arm is released or the corer hits bottom. As soon as the core has been obtained, the corer should be slowly pulled free of the bottom and then returned to the surface as rapidly as possible. If the corer is relatively short with sufficient deck space and lifting clearance available, the corer should be retained in a vertical orientation until the core has been removed. As soon as the core cutter has been disconnected from the core barrel, the core liner can be removed. However, if the check valve creates a tight seal at the top of the sample, it may be necessary to break the suction before removing the core to prevent core disturbance. After the core liner has been removed from the corer, it should be capped, labeled, and stored as suggested in the section on core handling. The field logs should be updated in a timely manner.

Vessel requirements for deploying gravity corers will vary slightly, depending upon the specifics of the corer. Generally, the lifting equipment should be capable of handling the weight and the height of the full corer and the tripped cable, if a trip arm is used. The requirement for keeping the vessel at a fixed location is not critical unless it is necessary to sample a specified point; however, the vessel should not be permitted to move so far away from the embedded corer that it is pulled up at an angle.

The advantages of gravity corers include the ease of handling and the simplicity of operation. The principal disadvantage is the short sample length. The difficulty of obtaining a longer core is caused by selective sampling; as the gravity corer penetrates the formation, the sidewall friction between the

sediment and the liner builds up and eventually causes a plug to form at the core cutter. In an attempt to sample deeper sediments with a gravity-type corer, a piston was added; the piston-type gravity corer is discussed in the following paragraph. It is appropriate to note herein that Hvorslev (1949) recommended the maximum length-to-diameter ratio for an undisturbed sample of cohesive soil should be of the order of 10 to 20; for offshore investigations, the length-to-diameter ratios are frequently much larger. Perhaps, the excessive length-to-diameter ratios may cause increased sample disturbance.

(b) *Piston-type gravity corers.* A diagram of a typical piston corer is shown in Figure 10-14. The purpose of the piston is to remain at the top of the sediment and create a suction as the core barrel is pushed into the sediment; the effect of the suction is to enhance the recovery of the core and perhaps increase the length of the sample drive. As with the gravity corer, the piston corer has either a permanent weight or an adjustable set of weights at the top. Most piston corers can be used to obtain a 6.3- to 6.7-cm- (2-1/2- to 2-5/8-in.-) diam core; the length of the core is usually 3 to 15 m (10 to 50 ft), depending upon the type of sediment, although cores up to 40 m (130 ft) in length have been obtained. The length of the piston corer can be adjusted by adding 3-m (10-ft) lengths of core barrel and using longer plastic liners.

With the exception of a few steps for the operation of the piston, the operation of the piston-type gravity corer is similar to the operation of valve-type gravity corer, as noted in Figure 10-13. After the piston corer has been assembled according to the manufacturer's instructions, three additional steps are required before the sampler is deployed: the trip wire length should be adjusted, the clearance of the lifting equipment should be checked, and the core barrel should be filled with water. The length of the trip wire should be preset before the sampler is deployed to ensure that the piston is stopped and held at or slightly above the sediment surface as the core barrel penetrates the formation. The length of the trip wire can be calculated by Equation 10-1:

$$L_t = V_t + L_c + F_c - (l_t - d_t) \quad (10-1)$$

where

L_t = length of the trip wire

V_t = vertical distance the trip or trigger arm must move to release the corer

L_c = overall length of the corer

F_c = free-fall distance the corer travels before it impacts the seafloor sediment

l_t = overall length of the trip or trigger weight

d_t = depth of penetration of the trigger weight into the seafloor sediment

After the sediment has been sampled, about 0.3 to 0.6 m (1 to 2 ft) of water should be separating the top of the sediment and the bottom of the piston. This separation assures that the top sediments have been sampled. If the distance between the sediment and the piston is too large, the free-fall loop is too short or the length of the trip wire is too long; then the length of the wire(s) should be adjusted by an amount equal to the length of the excess distance between the piston and the core. If the mud marks on the outside of the corer indicate a significantly greater penetration depth than the length of the core retrieved,

the free-fall loop should be shortened an amount equal to the difference between the core length and the penetration depth.

Typically, the length of the trip wire is 3 to 6 m (10 to 20 ft), depending upon the overall length of the corer and the depth of penetration of the trigger weight into the seafloor sediment; the latter value is usually 0.6 to 1.2 m (2 to 4 ft). The required clearance of the lifting equipment on the work platform can be estimated as the sum of the length of the trip wire plus the length of the core tube. Short-piston corers, e.g., 3-to 6-m (10- to 20-ft) core length, can be deployed from a small crane or an A-frame, although it may be necessary to drag the sampler across the deck. For longer piston corers, it will be necessary to drag the device across the deck and upright in the water. After the sampler is suspended in the water and the trip weight has been deployed, the core barrel should be filled with water to prevent hydrostatic pressure from pushing the piston up as the device is lowered in the water.

After the sampler has been retrieved, the core cutter must be removed, the cable attached to the piston should be disconnected, and the bottom end of the liner containing the core catcher should be cut off. After the bottom of the core has been sealed, the plastic core tube should be removed from the sampling device. When the liner is removed from the barrel, the piston stop should be detached from the liner and the top of the sample tube should be sealed. The length of the core should be measured, the length of tube containing the core catcher should be noted, and the field logs should be updated. When cores longer than 3 m (10 ft) are obtained, the core liner should be pulled out a short distance, cut off, and sealed and labeled as each segment is removed. Core barrel sections can also be removed as needed as the liner is removed from the sampler. Although the sampler must be placed horizontally to remove the core liner, the sections of core should be turned upright as soon as possible and the top of each segment should be marked.

Although high-quality samples of cohesive sediments can be obtained with the piston corer, two sampling problems may occur: flow-in and piston surge. Flow-in occurs when the corer has not fully penetrated the sediment, usually when the piston is located somewhere in the middle of the core barrel. As the wireline is pulled upward to retrieve the corer, the piston is pulled to the piston stop before the sample tube is moved; this movement creates a suction in the core liner which tends to draw sediment into the core barrel. The flow-in sediment, which is very difficult to distinguish from the actual core, is disturbed. Fortunately, this problem can be minimized by the use of a split piston. When the split piston is utilized, an upward pull on the line causes the piston to separate; the main piston locks at the top of the sediment, and the secondary piston slides upward until it rests against the piston stop. Piston surge occurs when the piston is moved as the core barrel is penetrating the sediment. Ideally, the piston remains motionless during the sampling operation. However, the wireline is stretched by the weight of the sampler as the device is deployed. When the corer is tripped, an elastic wave travels up and down the wire and causes movement of the piston. Movement of the piston is also caused by the motion of the vessel. Presently, there is no universally accepted method for solving the piston motion problem.

(4) *Vibratory corers.* Over the years, many bottom-resting samplers have been built and used to obtain seafloor samples. Most of these devices were one-of-a-kind tools that eventually fell into disuse and no longer exist. However, vibratory-type corers have remained popular and are used extensively. Although several vibratory corers are commercially available, only typical vibratory corers are discussed herein. See paragraphs 7-5 and 8-2 for additional information on vibratory samplers.

The vibratory corer consists of a vibratory head attached to the top of the core barrel. The corer is supported in a bottom-resting frame which helps to ensure that the core barrel enters the sediment vertically as well as doubling as a reaction for advancing the sampling tube. The combination of weight

and vibration is generally used to drive the core barrel into the sediment, although vibrations can be combined with impact driving for some types of devices to increase the penetration. The vibrator can be electric, pneumatic, or hydraulic. The sizes of cores range from 76 to 152 mm (3 to 6 in.) in diameter by 3 to 12 m (10 to 40 ft) in length.

The vibratory corer should be operated and deployed according to the manufacturer's instructions. Care is needed to ensure that the inside of the core barrel is washed thoroughly before a new core liner is inserted to prevent the liner from becoming wedged against the walls of the core barrel. After the liner has been inserted, the threads should be cleaned before the collar is attached. Before the sampler is lowered to the ocean floor, the length of wireline to deploy the sampler should be calculated. For certain devices, deployment of the wireline is double the length of the core; this design feature must be considered when the length of the line and the sample drive are calculated. Once the corer has reached full penetration or refusal, the corer should be retrieved and placed on the work platform. When the liner has been removed from the core barrel, the cores can be cut into sections and sealed or opened for a visual analysis, as required. If extremely long cores have been taken, it may be necessary to detach a section of the core barrel to facilitate the removal of the core liner. If a full core was not obtained, the water on top of the sample should be drained by cutting the liner above the top of the sample before the sample is handled or sealed.

The vibratory corer can be operated in most coastal waters, and a sample can be obtained in most types of sediment. The time required to obtain a core depends on the density of the sediment. However, the core is disturbed to some degree; the degree of disturbance depends on the corer as well as the type of sediment. An example of a disturbed vibratory core is shown in Figure 10-15; the thin horizontal layers of dark sediment are curved downward due to disturbance. When sampling is conducted in nearshore areas, foreign objects, such as timbers or concrete, are sometimes encountered. These obstacles prevent the corer from obtaining a full core and sometimes damage the core barrel.

c. Drill string samplers. Drill-string samplers, as the name implies, operate through a drill string. Because these samplers are covered in detail in Chapters 5 through 8, this section presents only the unique aspects of their use for offshore investigations. Drill-string samplers require an onshore type of drill rig which is installed on a drill ship for use in deep water or placed on a temporary work platform. The work platform for the drill rig can vary from a small float or scaffolding to a large offshore workboat; the size of the platform is dependent upon the size of the drill rig and the support equipment required. The problems of using drill strings deployed from a work platform or vessel include the movement of the drill string as the platform is tossed about by the seas and the need to maintain a constant bit pressure appropriate for the soil type. To minimize these problems, power swivels, as illustrated in Figure 10-16, have been used.

(1) *Vertical stabilization of the drill string.* Three techniques to stabilize a drill string against vertical movement are available: (a) a heave compensator can be used on the vessel; (b) the drill string can be clamped to the seafloor; or (c) the drill string can be anchored to the formation with an inflatable packer. A schematic diagram of each method is presented in Figure 10-17. Heave compensators are devices that damp out vessel motion relative to drill-string movement with an hydraulic ram; these devices can be attached to either the crown block or the traveling block. A crown-block heave compensator can control approximately 1.5 to 6.0 m (5 to 20 ft) of heave, whereas a traveling-block heave compensator can control approximately 1.8 to 3.6 m (6 to 12 ft) of heave. Very heavy, hydraulically operated clamps which rest on the seafloor add to the reaction force available to the drill string and provide a means to reenter the borehole, if necessary. However, these devices are rather difficult to deploy, and the support equipment requires extra deck space. An inflatable packer,

commonly known as a down-hole anchor, can be attached to the drill string just above the bit and inflated against the borehole walls during the sampling process. The device is activated by a “latch-in” sampling tool and pressurized by drilling mud. When sampling is complete, withdrawal of the sampling tool causes the packer to deflate.

(2) *Operating without motion compensation.* If a motion compensation system is not available, the sampling tools, which are illustrated in Figure 10-18, can be used. These tools include a wireline-percussion sampler, a latch-in push sampler, and an hydraulic-piston sampler. The wireline-percussion sampler consists of a sliding weight and a sampling head to which sample tubes can be attached. To obtain a sample, the weight is raised with the wireline and then allowed to free-fall to drive the sampler into the formation. However, the “hammering” effect causes sample disturbance; therefore, the number of hammer blows is usually limited to approximately 30. The latch-in push sampler relies on a short sampling time to obtain a good sample without motion compensation. When the sampler is lowered into the borehole, a mechanism latches onto the drill string; the weight of the drill string is then used to push the tube to the bottom of the borehole. When the sampler is lifted, the latch mechanism releases and the sampler is retrieved on a wireline. Waves of too short a period will not allow sufficient time for the sampler to be recovered before it is again pushed into the formation by the weight of the drill string. The hydraulic-piston sampler is a jacking unit to which a 0.9-m- (3-ft-) long thin-walled sample tube has been attached. To obtain a sample, the jacking unit is lowered through the drill string until it latches onto the drill bit. Hydraulic pressure of the drilling fluid is then used to push the sample tube into the formation. During the sampling process, the piston rests on the sediment surface. After the sample has been obtained, the sampler is retrieved by a wireline.

10-6. Special Considerations for Underwater Sampling

When working in the marine environment, certain conditions require special attention. Because saltwater and saltwater mists are extremely corrosive, one of the most important aspects of any offshore geotechnical investigation is the cleaning and maintenance of the equipment. Other problems include sample recovery and storage and the difficulty of referencing the depth or elevation of bottom sediments. Selected topics are discussed in the following paragraphs.

a. Equipment cleanup. During offshore investigations, the sampling equipment as well as the vessel may require frequent washing to remove sediment, which can cause equipment to malfunction, and to prevent safety hazards on the deck. Saltwater obtained from a small water pump or from the saltwater tap on the vessel can be used for this purpose. However, at the end of the workday, the sampling equipment, including the wire ropes and any hand tools that were exposed to saltwater, should be hosed off with fresh water to prevent corrosion. If equipment is left underwater, sacrificial anodes should be attached to the equipment to counteract corrosion; locator pingers should also be attached to all equipment before it is deployed.

b. Corrosion resistant materials. Although most offshore coring equipment is constructed of corrosion-resistant materials, such as 316 stainless steel, the equipment needs to be maintained to remain operational and safe. If a new system is being designed for use in the marine environment, a metallurgist should be consulted early in the planning phase to assist in the selection of materials.

c. Wire rope. One of the most critical pieces of equipment for underwater sampling is the wire rope or wireline. Unfortunately, it corrodes easily when it has been exposed to saltwater and is then considered unsafe to use. Although galvanized wire rope is somewhat more corrosion resistant, it, too, will corrode when exposed to saltwater for a period of time. Therefore, most vessel and crane operators

are unwilling to dip crane hooks and wire ropes into the saltwater. Consequently, lifting straps, deployment wires, wire ropes, and other equipment required for the job must be supplied as an added cost to the project. A wire-rope catalog will provide information on the bending radius of the rope and the static working loads. A good rigger or rigging manual should be consulted for properly tying or terminating wire ropes. A torque-balanced wire rope which resists spinning when the equipment is lowering is also available.

d. Sample liners. Another consideration in offshore sampling is the type of plastic liner used in the sampler. The most commonly used liner is a clear plastic made of cellulose acetate butyrate (CAB). However, CAB is not very strong, can be easily damaged, and allows some moisture loss. Other plastics which have been used for core liners include rigid polycarbonate (Lexan) and polyvinyl chloride (PVC). As compared to CAB, Lexan is fairly strong, allows less moisture loss, and is more expensive; PVC is also fairly strong and allows little moisture loss, although it is opaque and contains heavy metals that could adversely affect the results of a chemical analysis of the soil sample. Some plastics can be custom extruded to meet the coring applications, whereas others can be obtained only in stock sizes. For extruded materials, there may be a minimum order or a tooling charge.

e. Core catcher. The most common type of core catcher is the mechanical “finger” type. The finger-type core catcher is relatively inexpensive and can be reused extensively provided that it is cared for. Although it works well in cohesive soils, cohesionless soils sometimes wash out as the core is brought to the surface. For hard-to-retain sediments, two other types of core catchers are available. The retainer, which is shown in Figure 10-19, uses a polyethylene sleeve affixed to the outside of a finger-type catcher; after the core has been obtained, the bag collapses to retain the sample. Figure 10-20 shows another type of core catcher which has a sphincter closure to retain the core. When a trip lever on the core barrel is released, a nylon sleeve which is located inside the core barrel is twisted to close the bottom of the core barrel.

f. Location of the bottom. Because underwater sediments progress from muddy water, to a pea-soup consistency, to mud, and eventually to a sediment with significant strength, one of the most difficult problems dealing with underwater sampling is determining the location of the “bottom” or the “mudline.” When sampling is done, especially in support of dredging operations, determining where the mudline starts is of great importance. A method of defining the location of the bottom should be selected and specified very clearly. One method is to use a flat steel plate of a specific dimension and weight; the bottom is defined as the point at which the plate comes to rest and does not move after a defined period of time. The plate should be attached to a specified lowering line for which the amount of stretch has been defined. An alternative method is to define the “bottom” as determined by a certain apparatus, such as a fathometer or a nuclear density gauge. Several U.S. Army Corps of Engineers Districts and Laboratories have experience with these devices.

g. Gas-charged sediments. Occasionally, gas-charged sediments, which are extremely difficult to sample without disturbance, are encountered offshore. Recently, samples of gas-charged sediments have been obtained with a sampler that retains the sample in a pressurized chamber. A drill-string wireline system is used to deploy the sampler. However, samples obtained in pressurized chambers are of little value unless the sample containers are opened and the samples are prepared for testing at conditions comparable to the in situ pressures; to achieve these conditions, the laboratory testing program can be conducted inside an hyperbaric chamber.

h. Sampling logs. As compared to the boring logs maintained for onshore investigations (see Chapter 13), the sampling logs for offshore operations require additional data such as the type of vessel

or platform; the navigation system and site coordinates; the time, depth of water, tides, and weather conditions; and the size and type of sampler and sampling procedures, including lowering and retrieval rates and the pullout load. An example of a data sheet that can be modified to meet the specific needs of an underwater sampling investigation is shown in Figure 10-21.

10-7. Sample Handling and Storage

In general, the methods for handling and/or storage of samples obtained during offshore drilling and sampling operations should follow the procedures used for onshore samples, which are described in Chapter 13 of this manual. However, special considerations are required for certain aspects of offshore investigations, including subsampling box core samples, handling long core samples, and the transport and storage of samples.

Because the size of the box core is fairly large and cannot be handled easily, subsamples of the box core should be obtained onboard the vessel prior to shipping the soil samples to the onshore laboratory. To subsample a box core, a piston, which can be attached to a rigid frame above the core, is placed on the top of the sample and is used as a guide for the tube that is pushed into the box core. The diameter of the subsampling tubes should be selected based upon the laboratory tests to be conducted on the subsamples. After all subsample tubes have been pushed into the box sample, the sediment around the tubes should be removed and saved for tests such as grain-size analysis and Atterberg limits.

Long cores that are obtained in plastic liners should be cut into segments 0.5 to 1.5 m (2 to 5 ft) long, depending on the proposed testing program, shipboard storage, shipping containers, and the estimated time for storage of the segments. In general, the length of the core should be decreased as the time for storage is increased to reduce settlement and leakage. As the liner is removed from the coring device, a permanent felt-tip marker should be used to mark the segments of the tube with a consistent labeling scheme, such as the bottom segment being labeled "1" or "a," etc.; each segment should also be labeled with an arrow pointing towards the top of the sample. After a segment has been labeled and the plastic liner has been cut, the segment should be measured and its condition noted; it should then be capped, taped with plastic tape, sealed with wax or plastic wrap and aluminum foil, and labeled. As a minimum, the label should contain the name of the project, the site number or name, the core number and segment number, the length of the segment, the date the core was taken, the depth of water, the sampler type, and any observations or problems. This information can be written on the plastic tube with a permanent marker, engraved into the plastic, or written on a card and inserted into a self-adhesive plastic bag attached to the core tube.

Samples should be stored and transported under conditions that minimize or prevent additional disturbance. Recall that core samples have already been disturbed by the change of stress and temperature as a result of being sampled at the relatively cool sea floor and recovered on the warm, and possibly even hot, deck. Cores should be stored vertically in a framework that prevents them from being jostled, and if necessary can be wrapped in plastic bubble wrap to cushion them from shipboard vibrations. The storage room should be maintained at a temperature of 2 to 4 deg C (35 to 40 deg F) with a relative humidity of 100 percent to prevent the growth of marine organisms. The method of packing the cores for shipment to the onshore laboratory should be preplanned to ensure that the shipping crates are designed to minimize core disturbance and the cores are sectioned to a standard length. The top of the shipping crate (hence, the top of the cores) should always be labeled "THIS END UP." Because calcareous samples are difficult to transport without causing severe disturbance, onboard testing of these materials is recommended, if possible.

10-8. Summary

Although numerous types of equipment are available for sampling offshore formations, a well-planned sampling operation can reduce the degree of difficulty and the expenses involved by ensuring that the proper equipment is available to obtain the required number of samples of satisfactory quality. Nearly all of the samplers discussed in this chapter can be used to sample cohesive materials. However, bottom-resting devices may sink under their own weight and therefore cannot be used for sampling soft sediments. For cohesionless soils, vibratory corers and wireline samplers can be used, although samples obtained with the vibratory corer are disturbed, whereas samples obtained with wireline samplers are fairly expensive. Specialized core retainers will help retain cohesionless soils in the sample tube. Rock sampling will likely require a drill-string sampler, although a few bottom-resting rock corers have been built for sampling the top of rock formations. Calcareous formations can be sampled by most of the devices discussed in this chapter. However, the effect of sample disturbance is unknown because the engineering behavior of calcareous materials cannot be predicted by conventional soil mechanics theory. Additional information on offshore sampling is available in the references cited in the section entitled "Bibliography" in Appendix A.

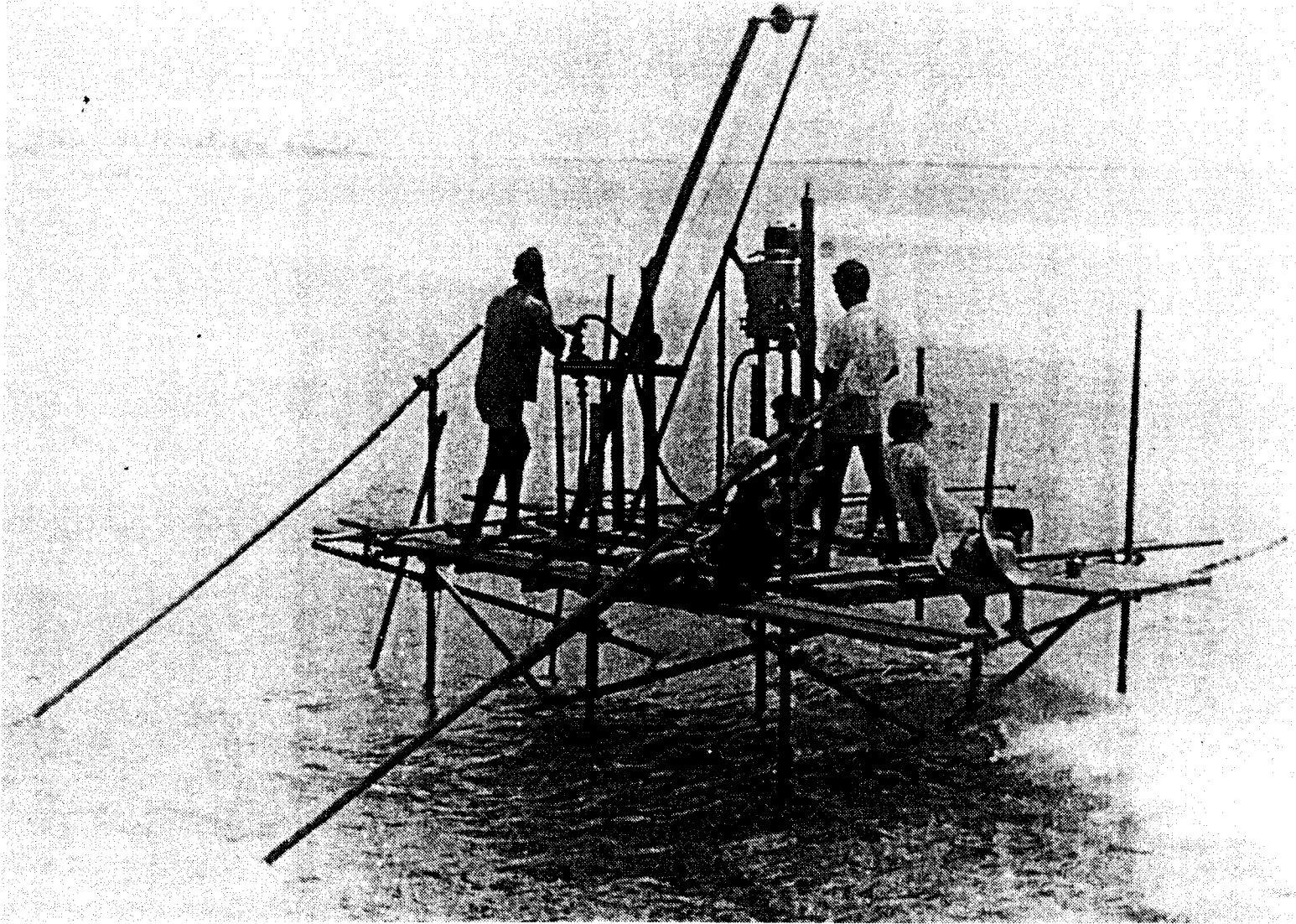

Figure 10-1. Photograph of a small drill rig on a scaffold. Note: Safety is a very important consideration for Corps of Engineer Projects. Safety items, including hardhats, gloves, safety shoes, protective clothing, life vests, and dust or vapor masks, should be worn, as appropriate, for the particular drilling and sampling operations. (Figure provided by the U.S. Naval Facilities Engineering Service Center)

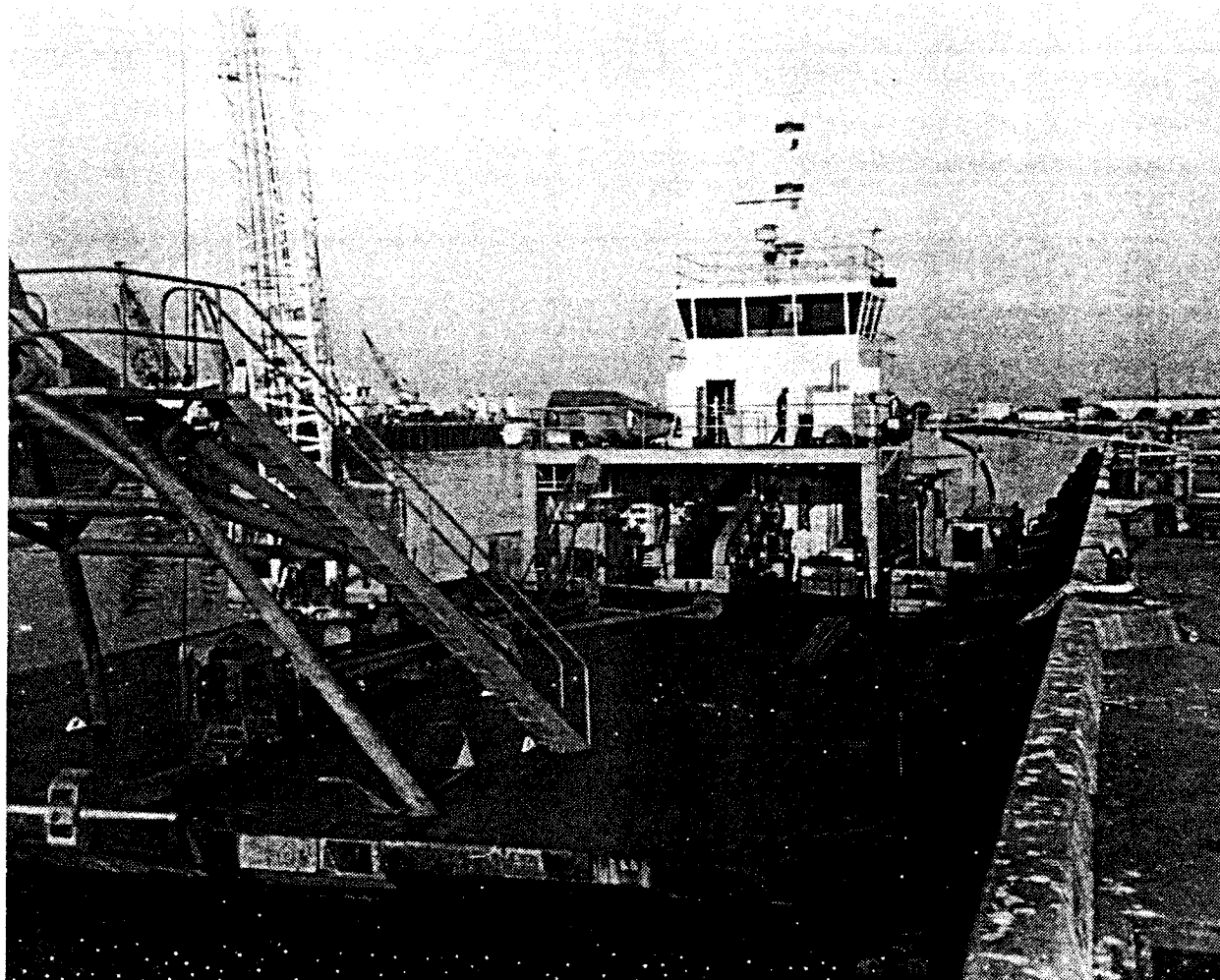

Figure 10-2. Photograph of a barge set up for nearshore work. Note the crane, A-frame, and winch for lifting and lowering drilling equipment. (Figure provided by the U.S. Naval Facilities Engineering Service Center)

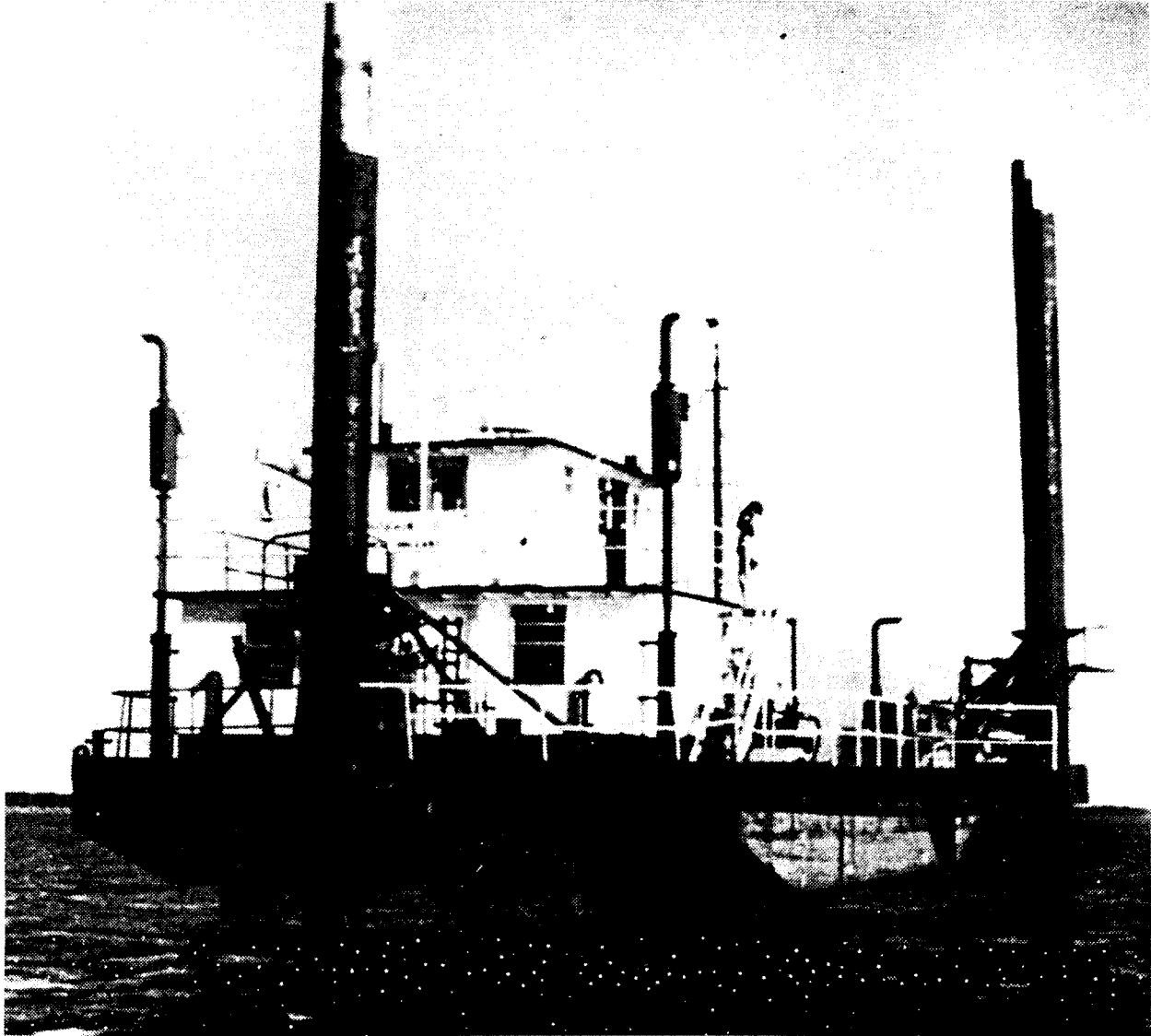

Figure 10-3. Photograph of a jack-up barge that can be used to support an onshore drilling rig. (Figure provided by the U.S. Naval Facilities Engineering Service Center)

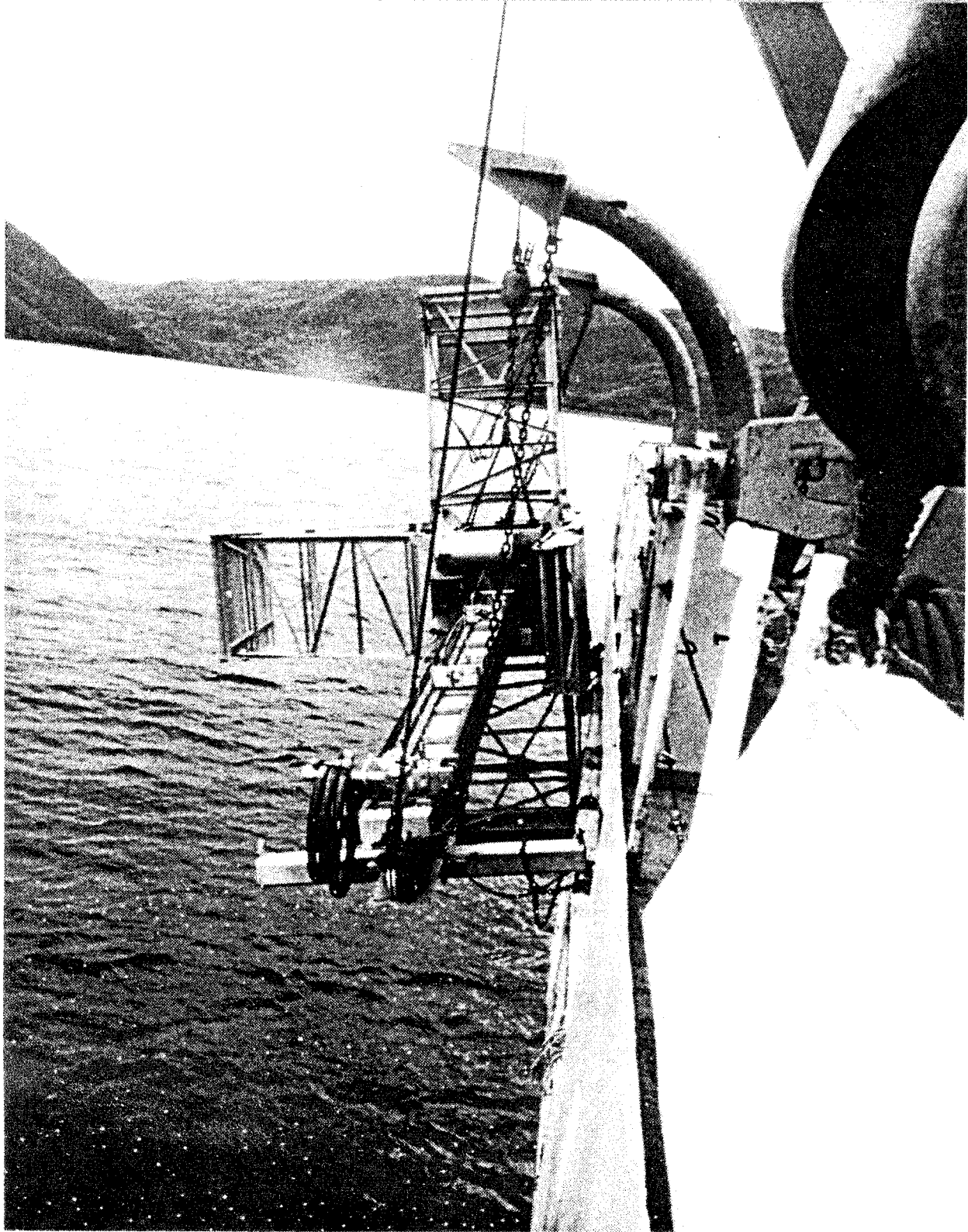

Figure 10-4. Photograph of a sampling device hung from a pair of davits along the side of a vessel. (Figure provided by the U.S. Naval Facilities Engineering Service Center)

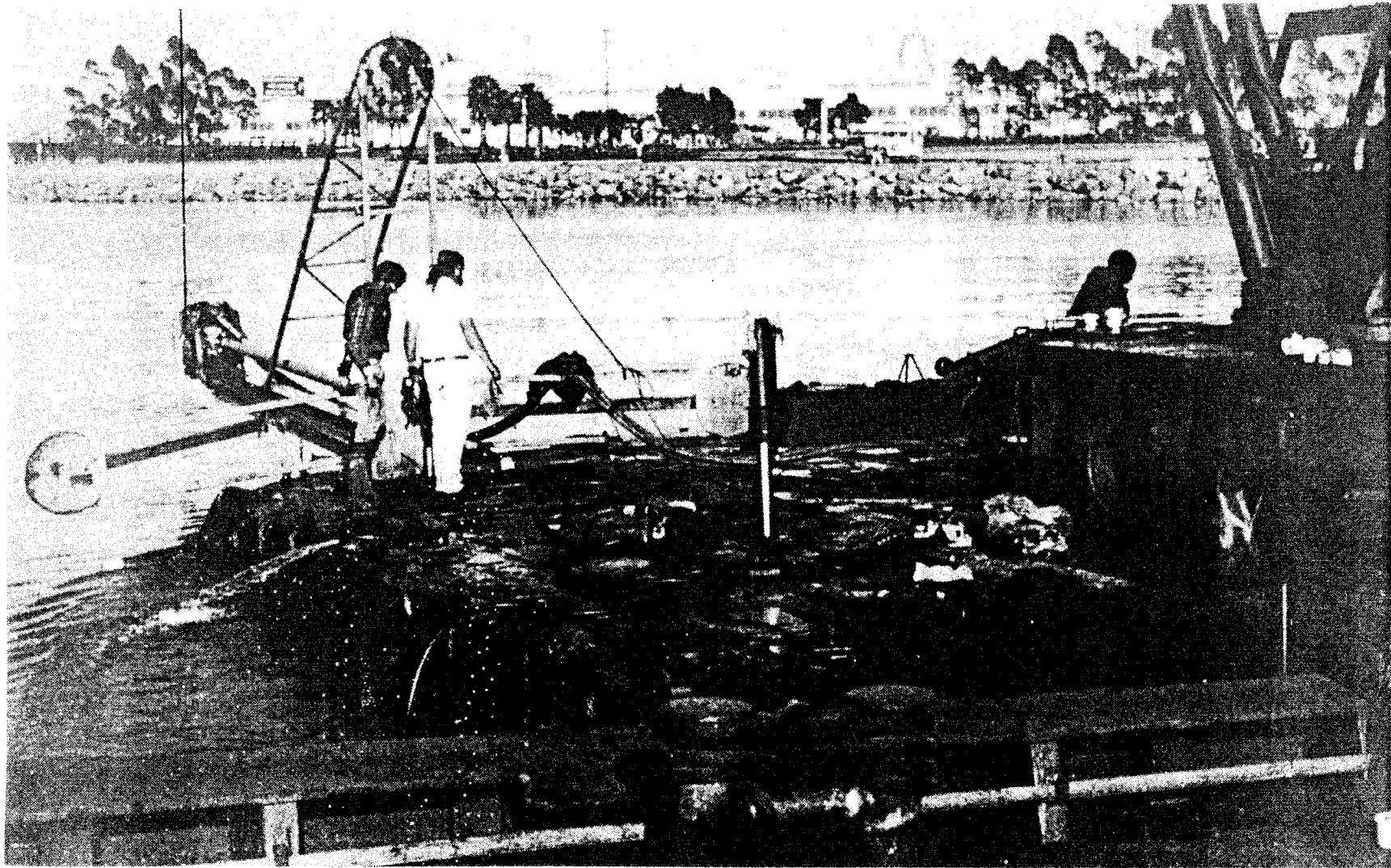

Figure 10-5. Photograph of a sampler being deployed with a mobile crane mounted on a barge. Because of insufficient deck space, the head of the sampler was supported over water by the crane while the base of the sampler was placed on the deck as the core was removed. Note: Safety is a very important consideration for Corps of Engineers projects. Safety items, including hardhats, gloves, safety shoes, protective clothing, life vests, and dust or vapor masks, should be worn, as appropriate, for the particular drilling and sampling operations. (Figure provided by the U.S. Naval Facilities Engineering Service Center)

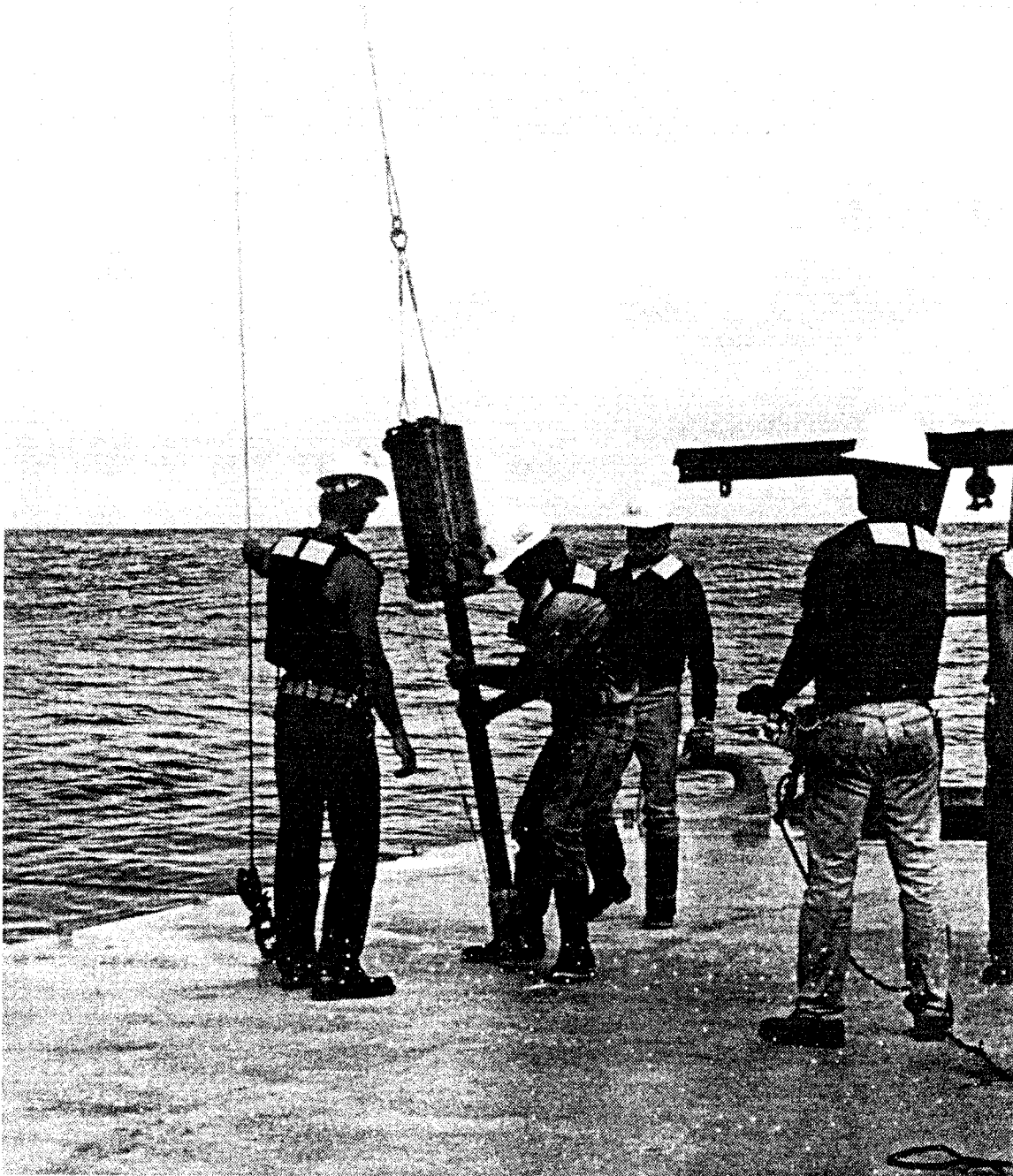

Figure 10-6. Photograph of a Boomerang corer. (Figure provided by the U.S. Naval Facilities Engineering Service Center)

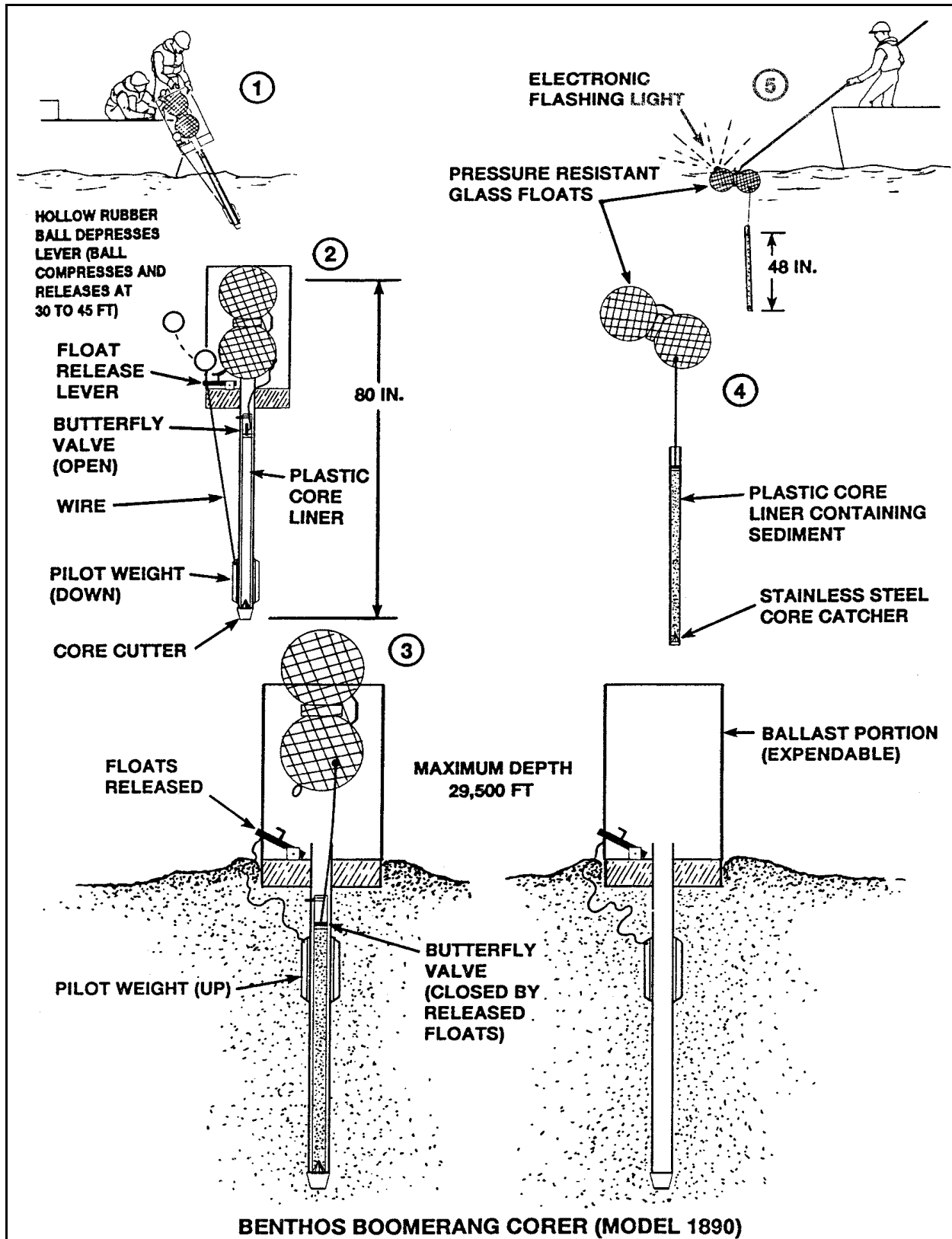
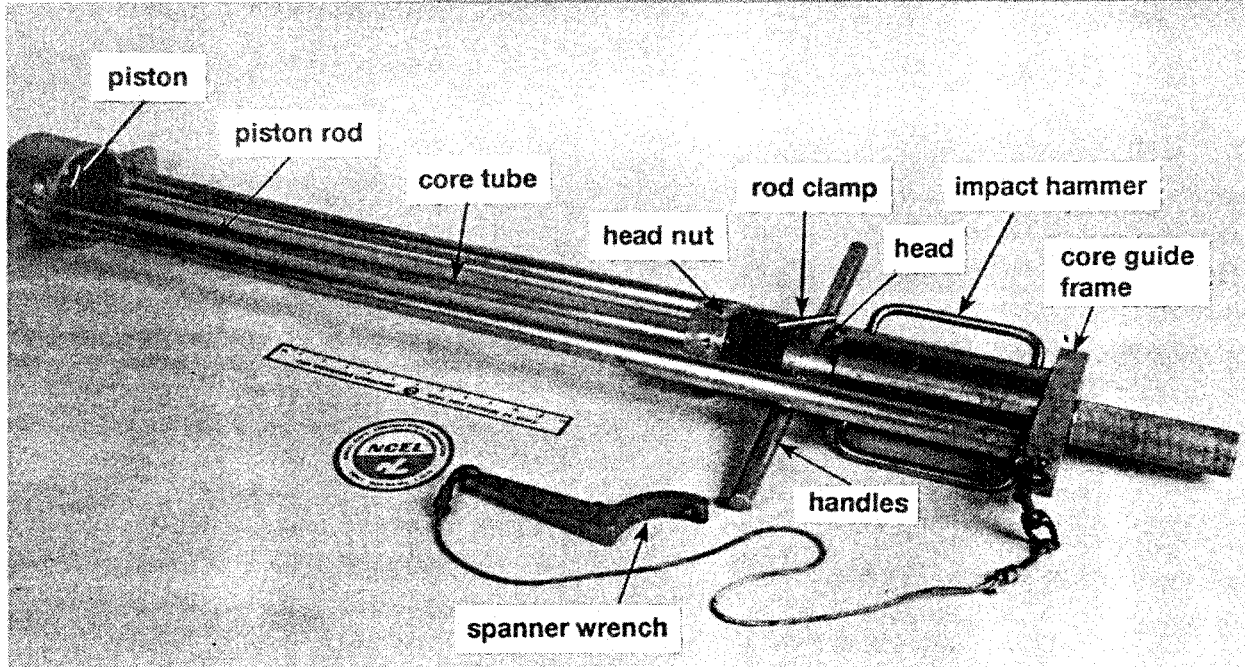
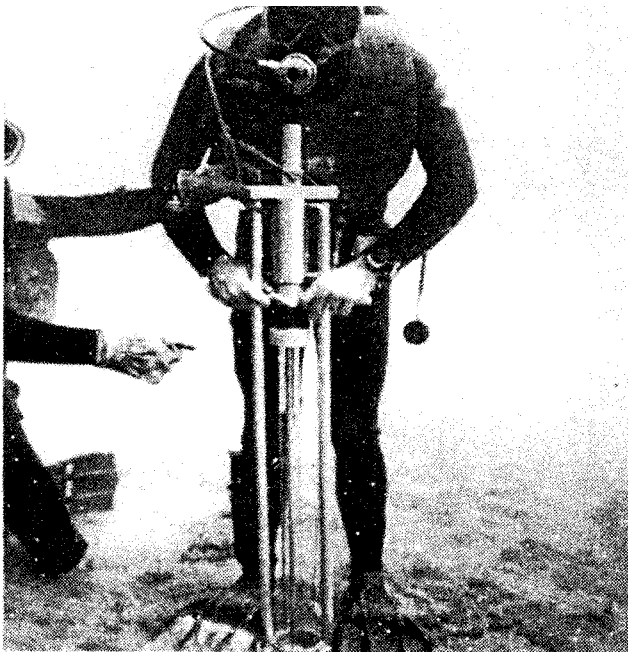

Figure 10-7. The operating sequence of the Boomerang corer. (Figure provided by the U.S. Naval Facilities Engineering Service Center)



a. Diver-operated corer with parts identified



b. Diver and partner operating corer underwater

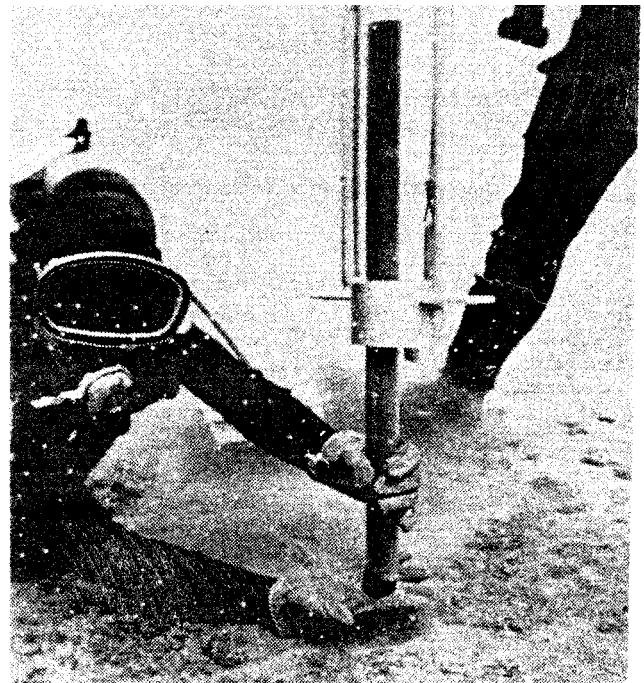

c. Divers capping bottom of core after pulling it out of the seafloor

Figure 10-8. Photograph of a hand-held diver-operated sampler available to government agencies through NAVFAC's Ocean Construction Equipment inventory. Note: Safety is a very important consideration for Corps of

EM 1110-1-1804

1 Jan 01

**Engineers projects. Safety items should be worn, as appropriate, for the particular drilling and sampling operations
(Figure provided by the U.S. Naval Facilities Engineer Service Center)**

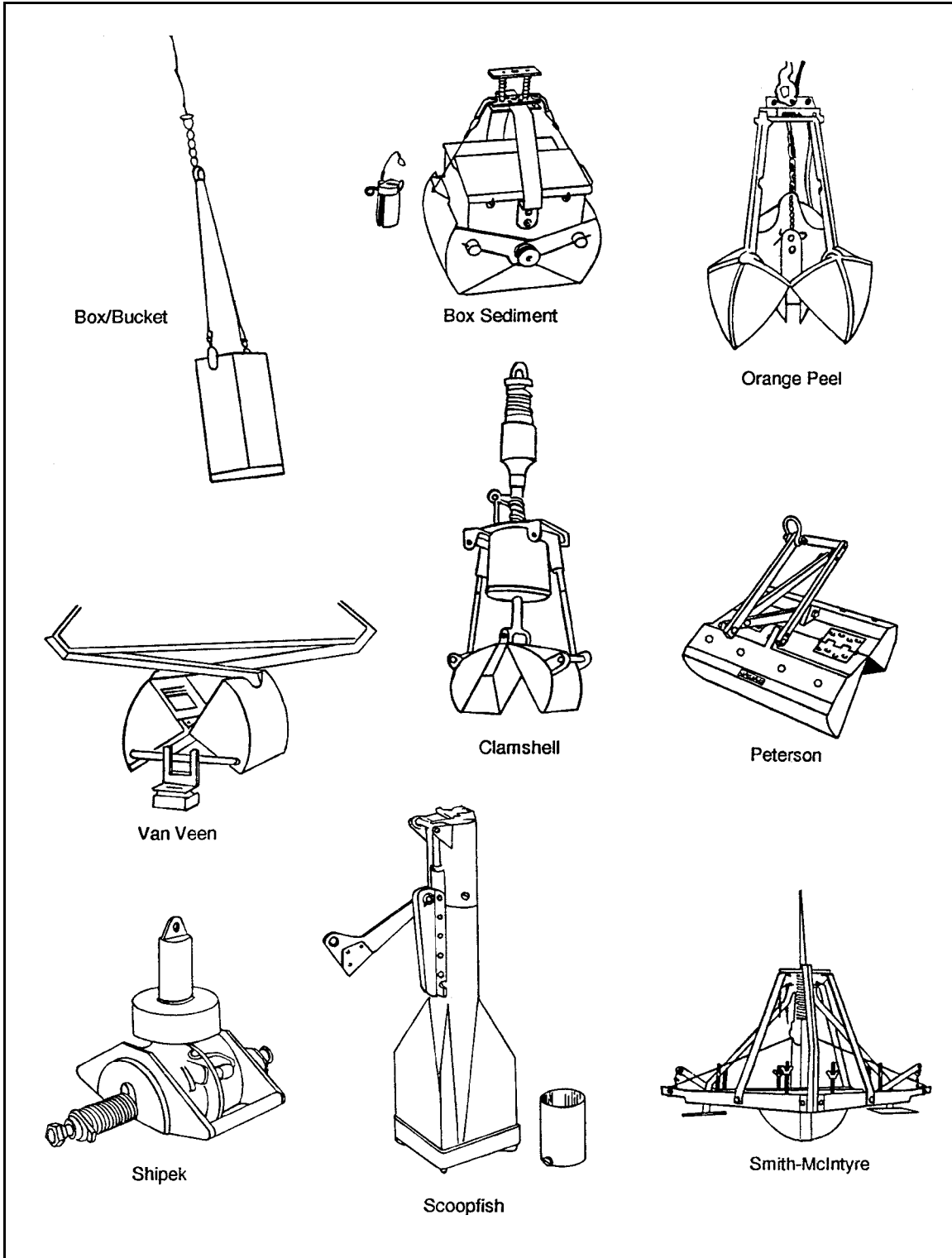

Figure 10-9. Schematic diagrams of several dredges and grab samplers that can be used to obtain disturbed, surficial sediment samples of the seafloor from almost any depth of water. (Figure provided by the U.S. Naval Facilities Engineering Service Center)

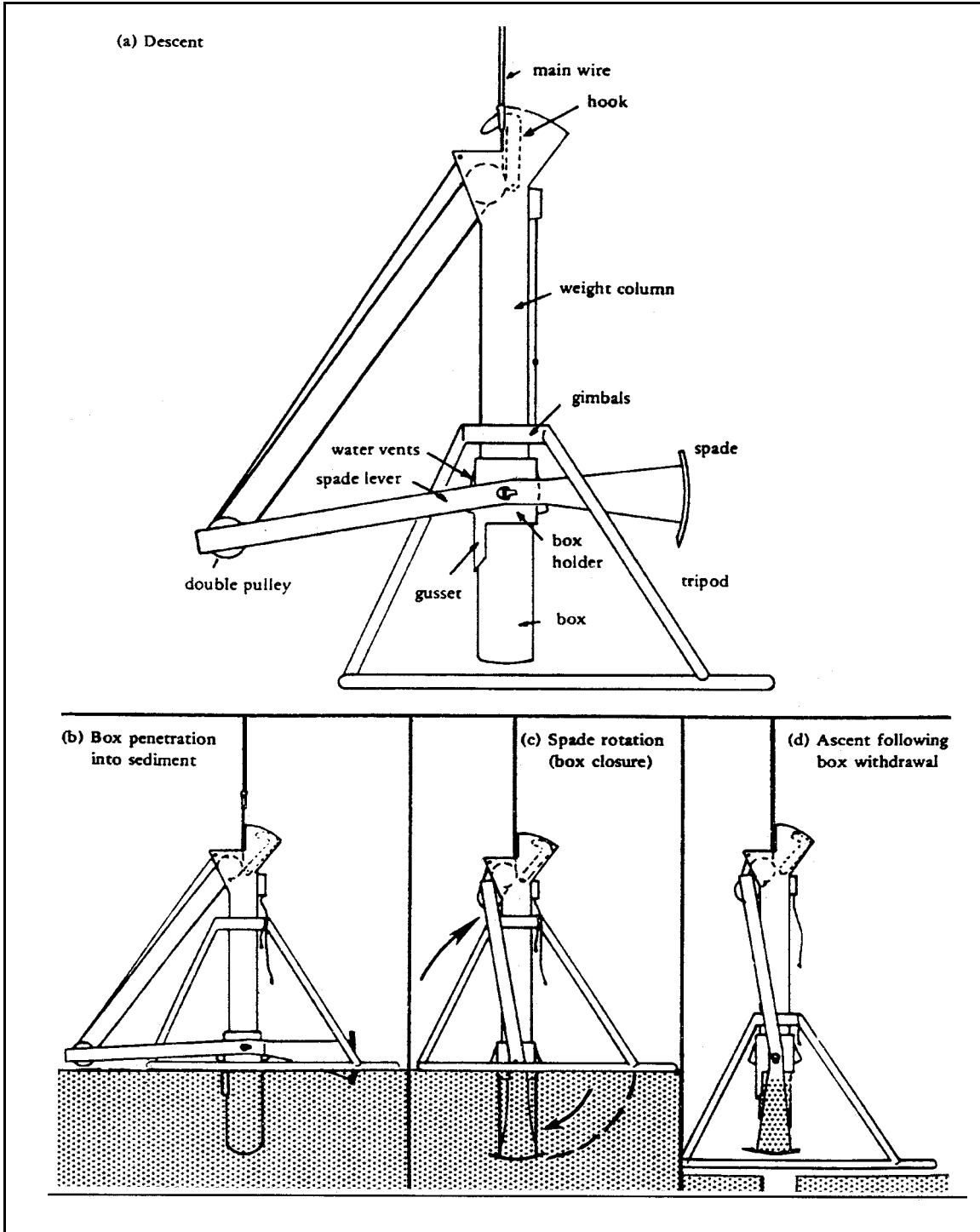

Figure 10-10. Conceptual presentation of the operating sequence of the box corer. (Figure provided by the U.S. Naval Engineering Service Center)

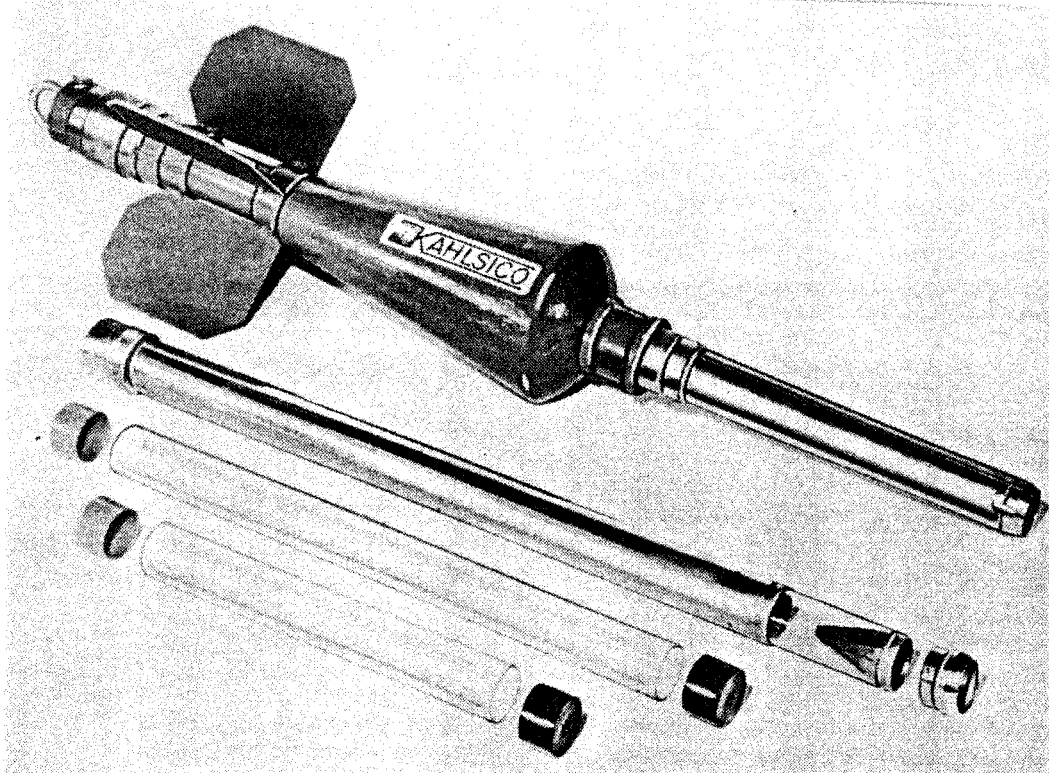

Figure 10-11. Photograph of the Phleger gravity corer. (Figure provided by the U.S. Naval Facilities Engineering Service Center)

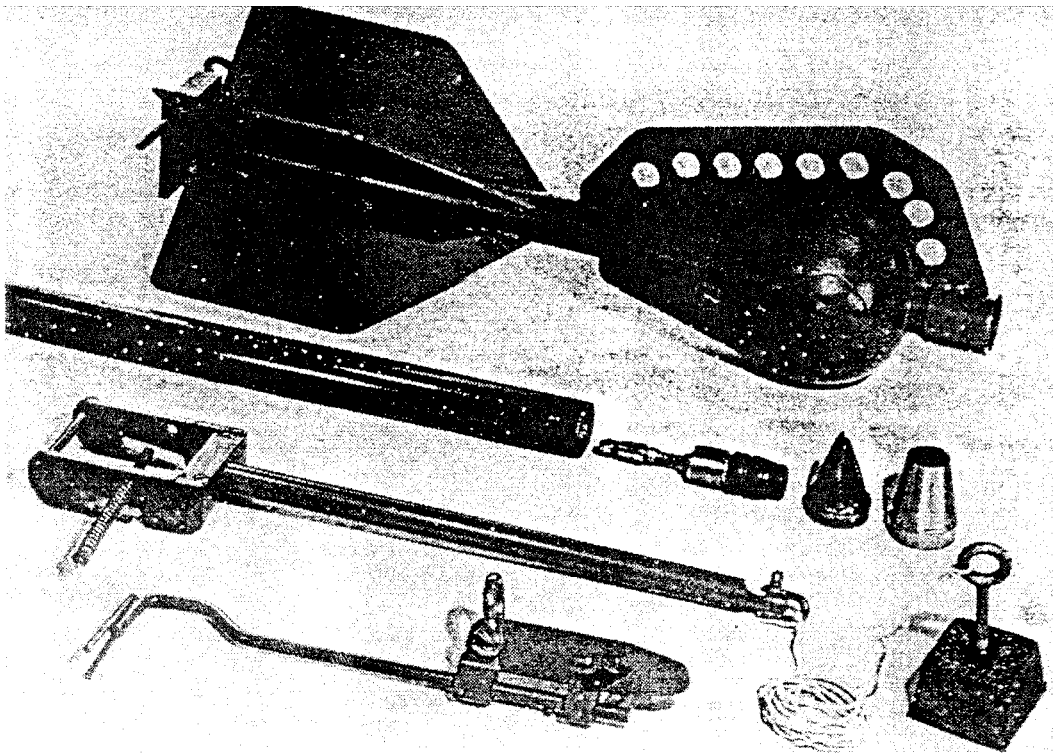
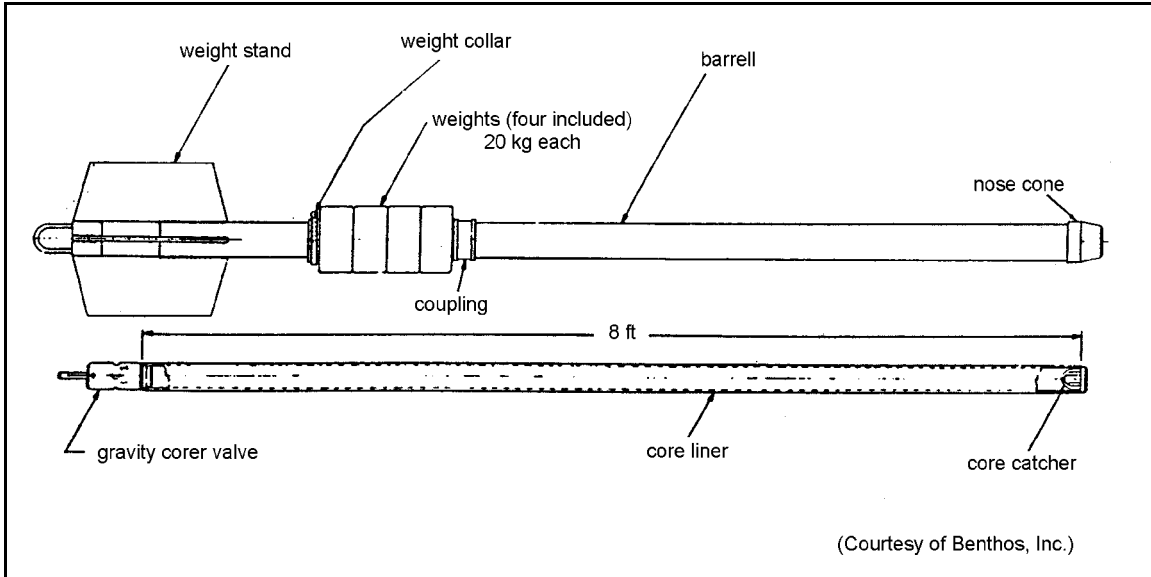

Figure 10-12. Ewing gravity corer. (Figure provided by the U.S. Naval Facilities Engineering Service Center)

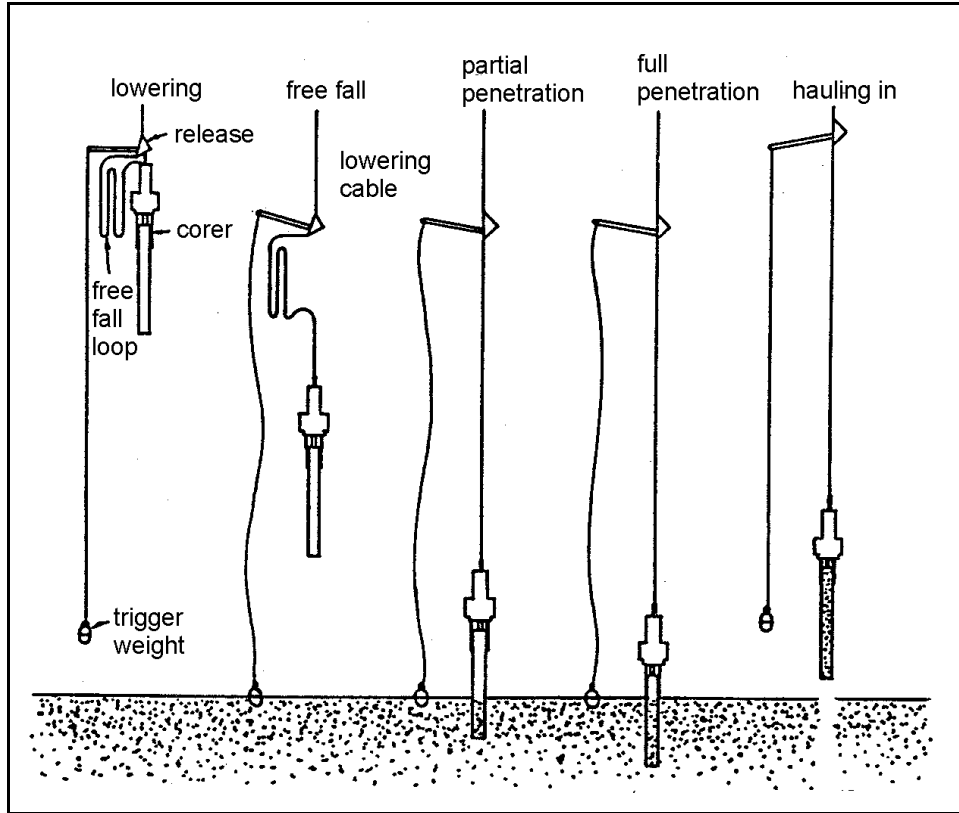

Figure 10-13. Schematic diagram of the trip arm release for operation of the check valve in a valve-type gravity corer. (Figure provided by the U.S. Naval Facilities Engineering Service Center)

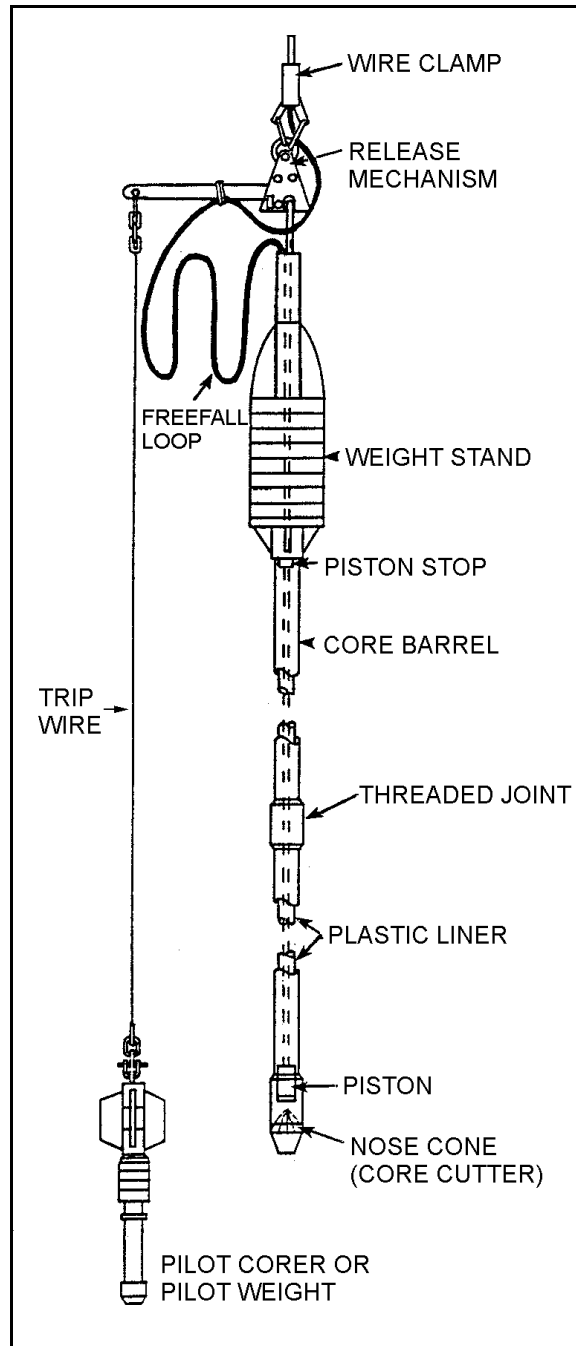

Figure 10-14. Schematic diagram of a typical piston-type gravity corer. (Figure provided by the U.S. Naval Facilities Engineer Service Center)

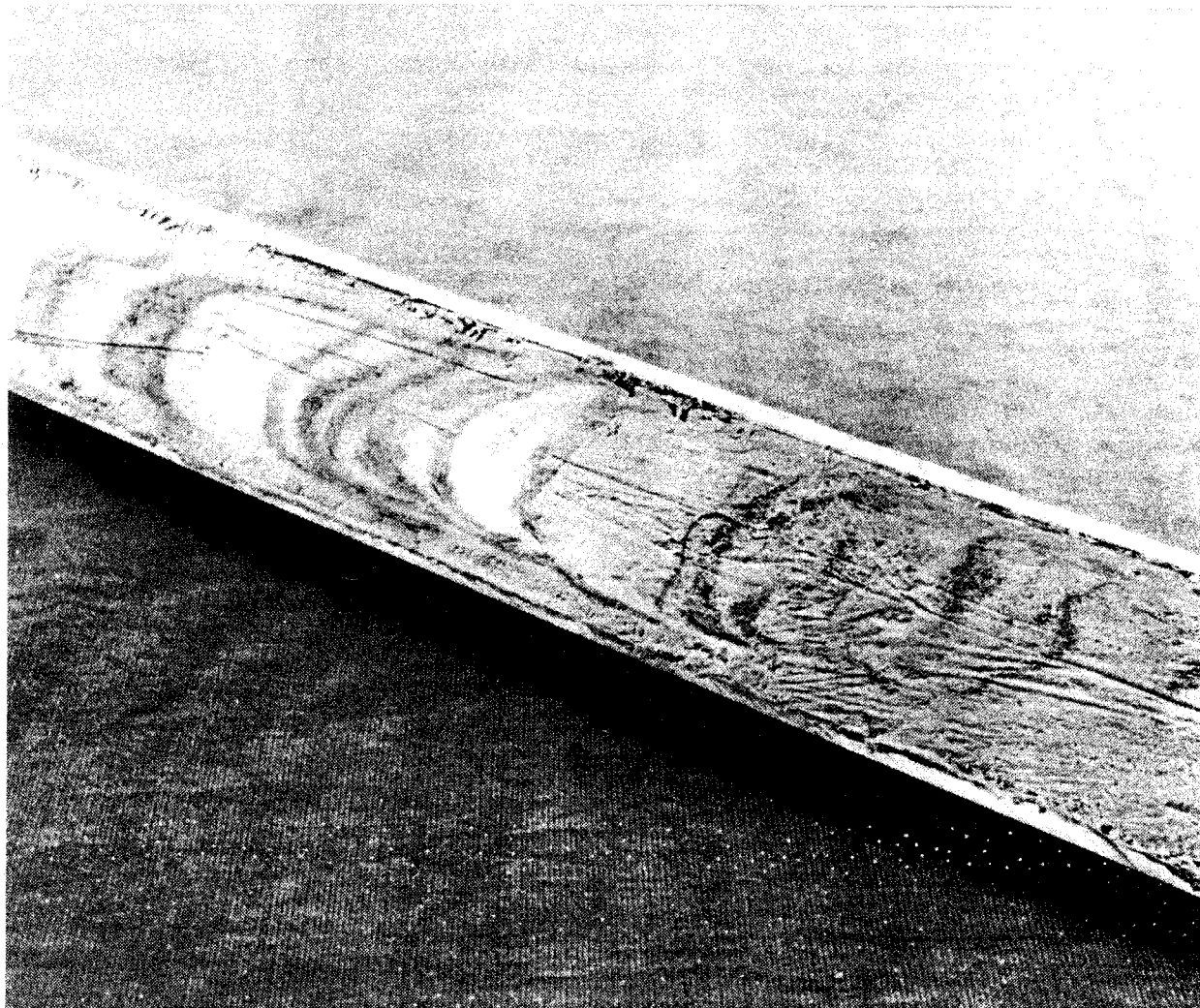

Figure 10-15. Photograph of a disturbed vibratory core. Note that the thin horizontal layers of dark sediment are curved downward due to sampling disturbance. (Figure provided by the U.S. Naval Facilities Engineering Service Center)

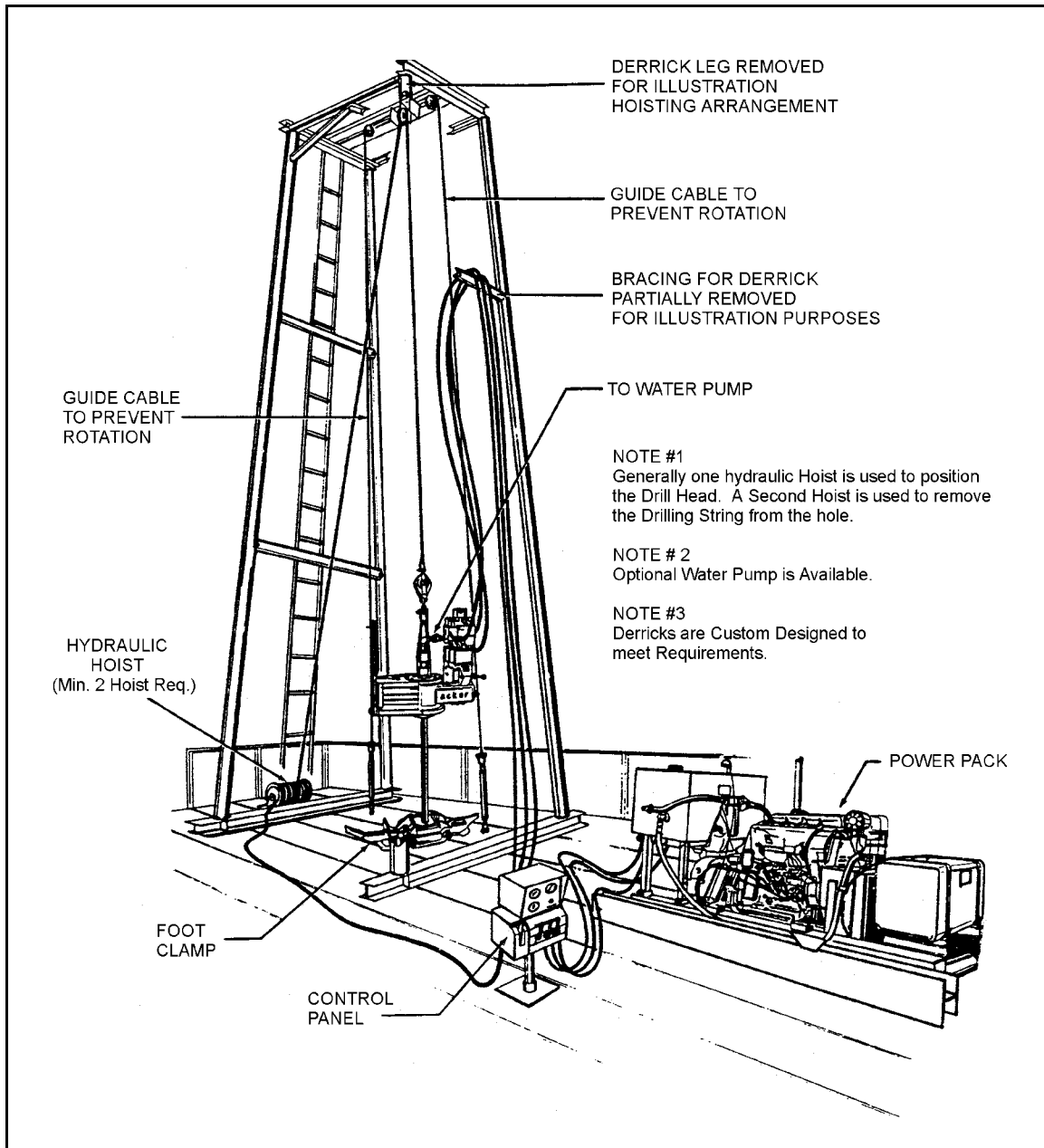

Figure 10-16. Schematic diagram of a custom-designed derrick with a power swivel which is used to minimize the movement of the drill string as the work platform or boat is tossed about by the seas. (Figure provided by the U.S. Naval Facilities Engineering Service Center)

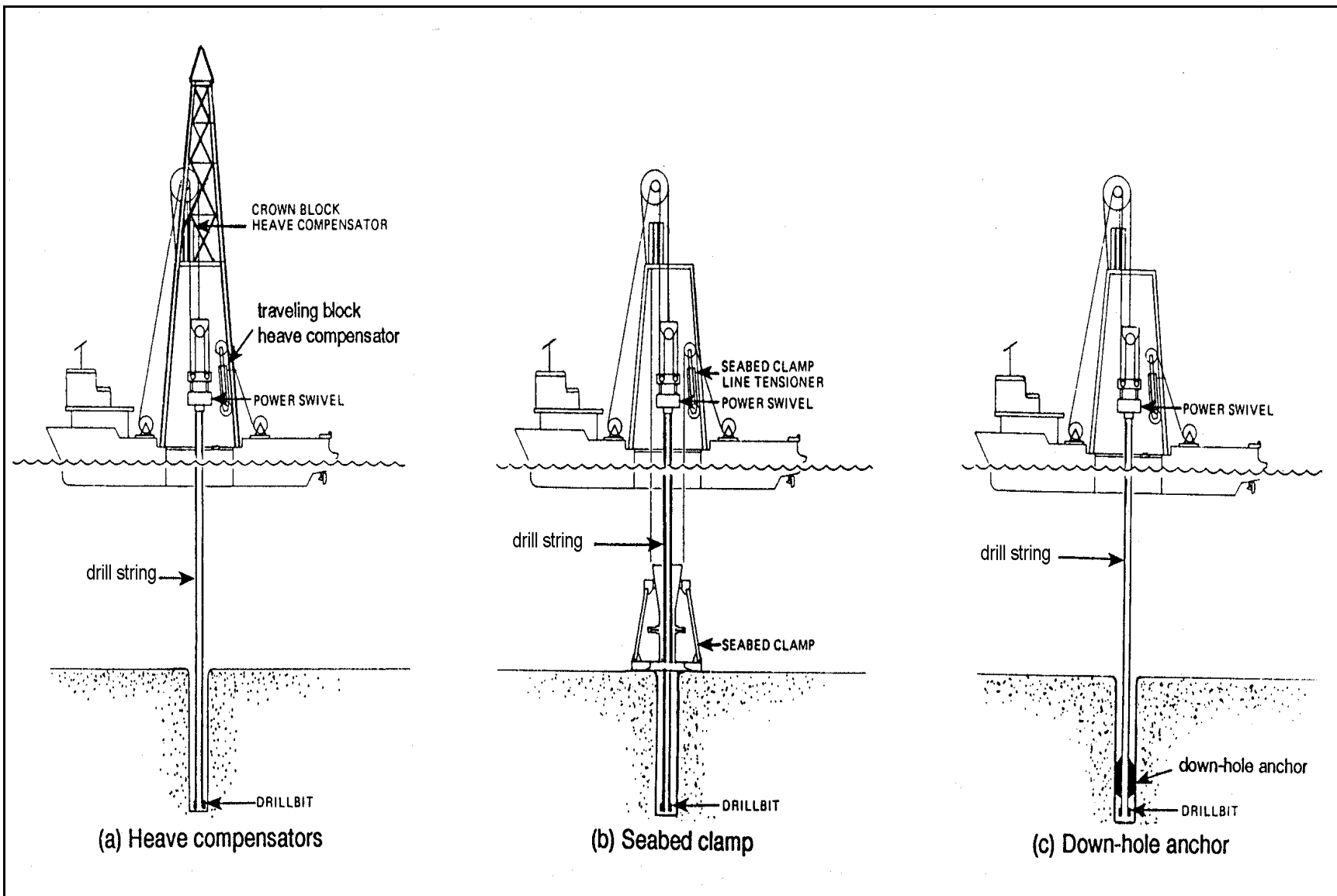

Figure 10-17. A schematic diagram of the three common techniques used to stabilize a drill string against vertical movement of the work platform. (Figure provided by the U.S. Naval Facilities Engineering Service Center)

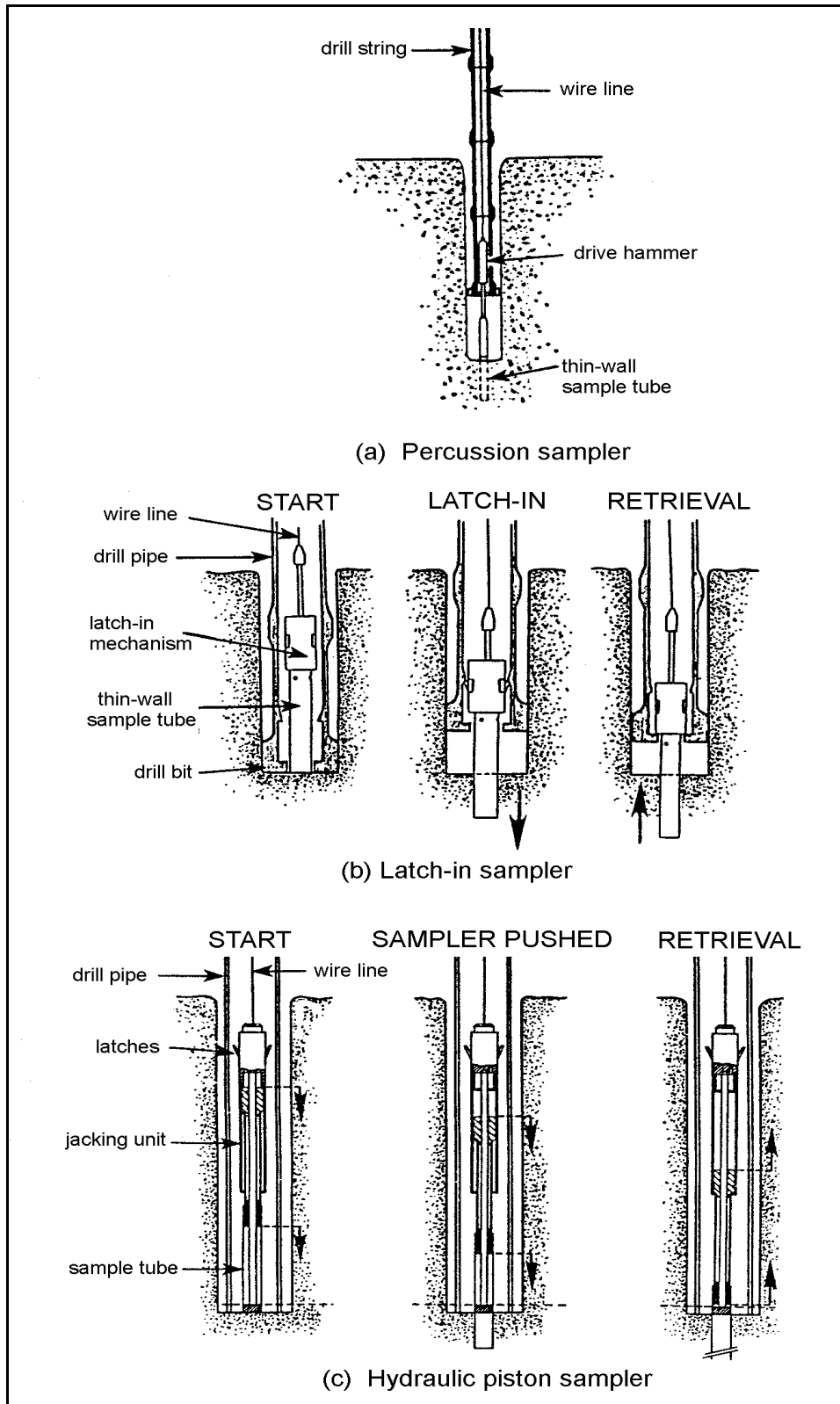
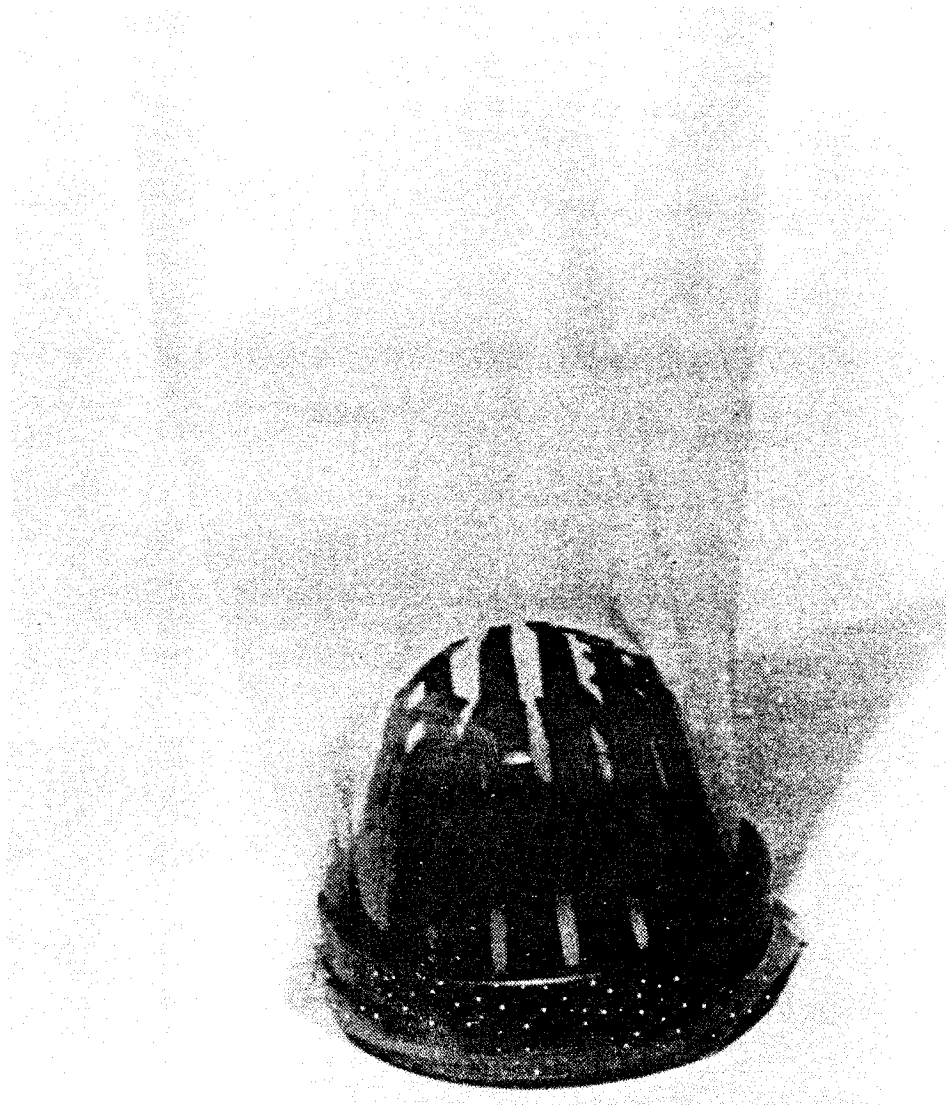

Figure 10-18. Wireline sampling tools which can be used if a motion compensation system is not available. (Figure provided by the U.S. Naval Facilities Engineering Service Center)



(Courtesy of Acker Drill Co.)

Figure 10-19. Photograph of a finger-type sample catcher with a polyethylene sleeve for retaining hard to sample materials. After the sample has been obtained, the bag collapses to help retain the material in the sampling tube. (Figure provided by the U.S. Naval Facilities Engineering Service Center)

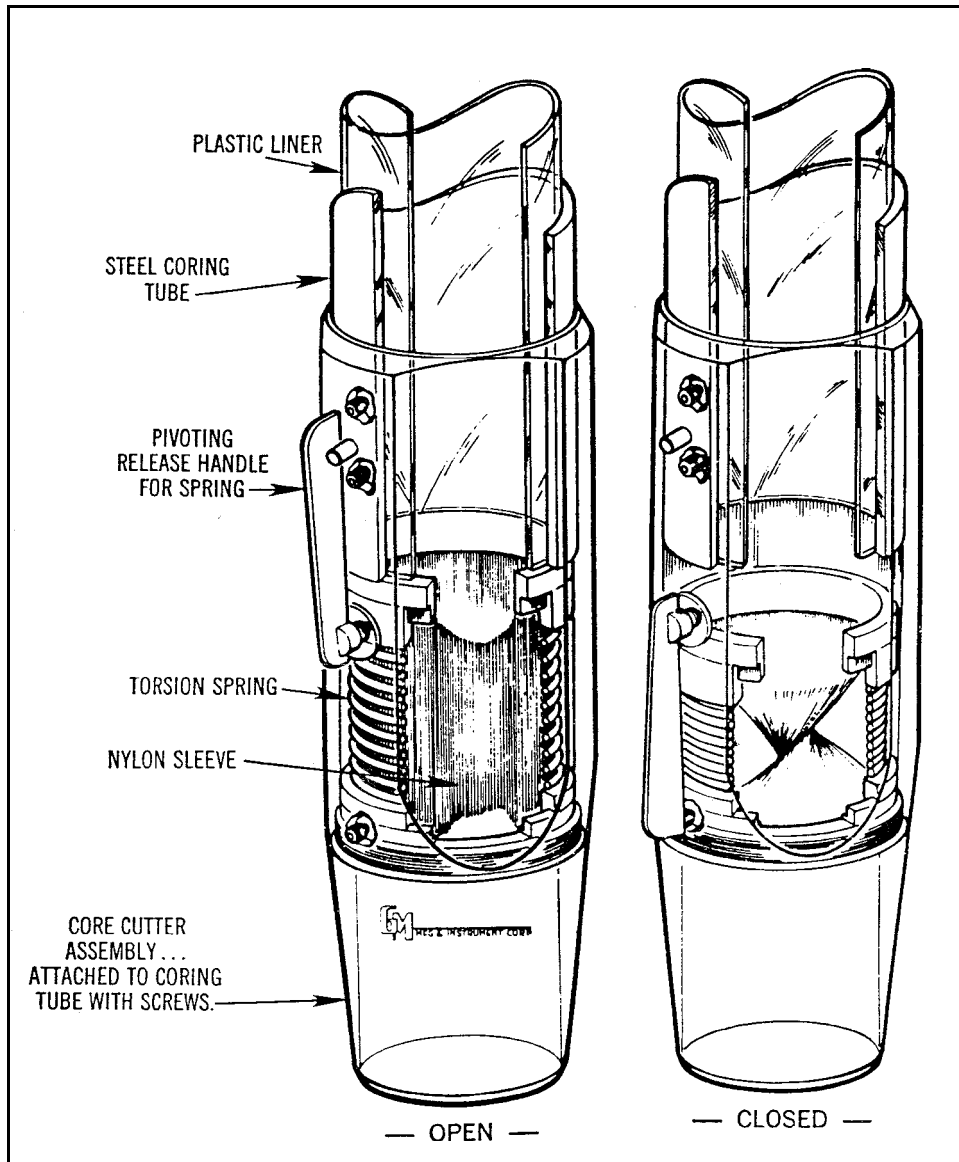

Figure 10-20. Isometric drawing of a core catcher with a sphincter closure to retain the core. (Figure provided by the U.S. Naval Facilities Engineering Service Center)

PROJECT/CRUISE _____		DATE _____	
VESSEL _____			
SITE DESIGNATION _____		WATER DEPTH _____	
NAVIGATION SYSTEM	COORDINATES	MEASURED WITH _____	
_____ X _____	Y _____	ORIGINAL _____	
_____ X _____	Y _____	CORRECTION _____	
_____ X _____	Y _____	CORRECTED _____	
SAMPLER TYPE			
<input type="checkbox"/> BOOMERANG	SAMPLER CAPACITY _____	TIME	
<input type="checkbox"/> DIVER CORER	BOX DIMENSIONS _____	START DOWN _____	
<input type="checkbox"/> GRAB/DREDGE	BARREL LENGTH _____	ON BOTTOM _____	
<input type="checkbox"/> BOX	FREEFALL LENGTH _____	START UP _____	
<input type="checkbox"/> GRAVITY-VALVE	TRIP WIRE LENGTH _____	ON DECK _____	
<input type="checkbox"/> GRAVITY-PISTON	AMOUNT OF WEIGHT _____	SPEED	
<input type="checkbox"/> VIBRATORY CORER	OTHER DETAILS _____	LOWERING RATE _____	
<input type="checkbox"/> DRILLSTRING	_____	RETRIEVAL RATE _____	
<input type="checkbox"/> OTHER _____	_____	PULLOUT LOAD _____	
SAMPLE DESCRIPTION: _____			
CORER PENETRATION DEPTH: _____			
SECTION #			
TOP	LENGTH	DESCRIPTION/CONDITION	
_____	_____	_____	
_____	_____	_____	
_____	_____	_____	
_____	_____	_____	
_____	_____	_____	
_____	_____	_____	
_____	_____	_____	
_____	_____	_____	
_____	_____	_____	
_____	_____	_____	
_____	_____	_____	
_____	_____	_____	
_____	_____	_____	
_____	_____	_____	
REMARKS (WEATHER, ACCIDENTS, EQUIPMENT PROBLEMS, ETC.) _____			

Figure 10-21. Data log form for an underwater sampling investigation. (Figure provided by the U.S. Naval Facilities Engineering Service Center)